

**LUDLUM MODEL 43-10-10  
ALPHA-BETA SAMPLE COUNTER**

**Addendum to Model 43-10-1 Manual  
April 2025**

**LUDLUM MODEL 43-10-10  
ALPHA-BETA SAMPLE COUNTER**

**Addendum to Model 43-10-1 Manual  
April 2025**



**LUDLUM MEASUREMENTS, INC**  
501 OAK STREET, P.O. BOX 810  
SWEETWATER, TEXAS 79556  
325-235-5494, FAX: 325-235-4672



## **STATEMENT OF WARRANTY**

Ludlum Measurements, Inc. warrants the products covered in this manual to be free of defects due to workmanship, material, and design for a period of twelve months from the date of delivery. The calibration of a product is warranted to be within its specified accuracy limits at the time of shipment. In the event of instrument failure, notify Ludlum Measurements to determine if repair, recalibration, or replacement is required.

This warranty excludes the replacement of photomultiplier tubes, G-M and proportional tubes, and scintillation crystals which are broken due to excessive physical abuse or used for purposes other than intended.

There are no warranties, express or implied, including without limitation any implied warranty of merchantability or fitness, which extend beyond the description of the face thereof. If the product does not perform as warranted herein, purchaser's sole remedy shall be repair or replacement, at the option of Ludlum Measurements. In no event will Ludlum Measurements be liable for damages, lost revenue, lost wages, or any other incidental or consequential damages, arising from the purchase, use, or inability to use product.

## **RETURN OF GOODS TO MANUFACTURER**

If equipment needs to be returned to Ludlum Measurements, Inc. for repair or calibration, please send to the address below. All shipments should include documentation containing return shipping address, customer name, telephone number, description of service requested, and all other necessary information. Your cooperation will expedite the return of your equipment.

**LUDLUM MEASUREMENTS, INC.  
ATTN: REPAIR DEPARTMENT  
501 OAK STREET  
SWEETWATER, TX 79556**

**800-622-0828 325-235-5494  
FAX 325-235-4672**

**LUDLUM MEASUREMENTS, INC.**

501 OAK ST. / P.O. BOX 810  
SWEETWATER, TEXAS 79556  
Phone: 325-235-5494 800-622-0828 (USA)  
Fax: 325-235-4672 E-Mail: ludlum@ludlums.com  
Website: <http://www.ludlums.com> FEIN 75-1085764

**DESIGNER AND MANUFACTURER****OF***Scientific and Industrial  
Instruments*

---

**Addendum for the Model 43-10-10 Alpha/Beta Sample Counter  
with iCam Filter  
(to the Model 43-10-1 manual)  
February 2020**

The Model 43-10-10 (part # 47-4114), which allows for counting of iCam air monitor filter cards, is very similar to the Model 43-10-1. Following are the differences:

1. The sample drawer (or tray) has a cutout that fits the iCam filter card. The dimensions of the iCam filter card are 5.1 x 8.8 x 0.064 cm (2 x 3.5 x 0.025 in.) (H x W x D). It can also fit a 60 x 4.7 mm deep (2.36 x 0.187 in.) sample.
2. Other new part numbers include:
  - Tube holder/Base assembly – part # 2142-303
  - Tray – part # 7142-320
  - Base plate – 7142-305
  - 60 mm spacer – 7142-329
3. See Drawing 142 x 301 (following this page) for overall dimensions.

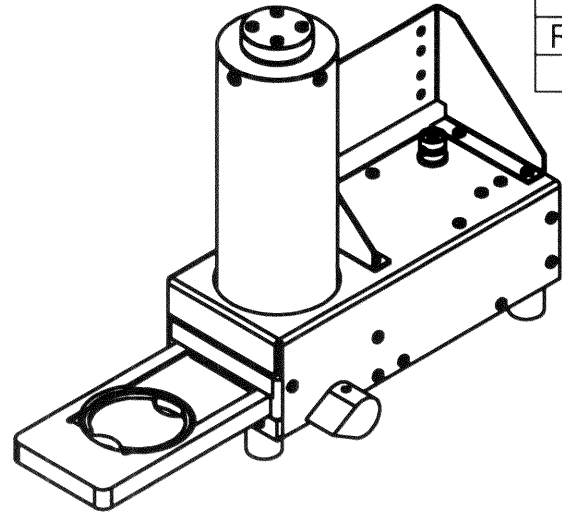
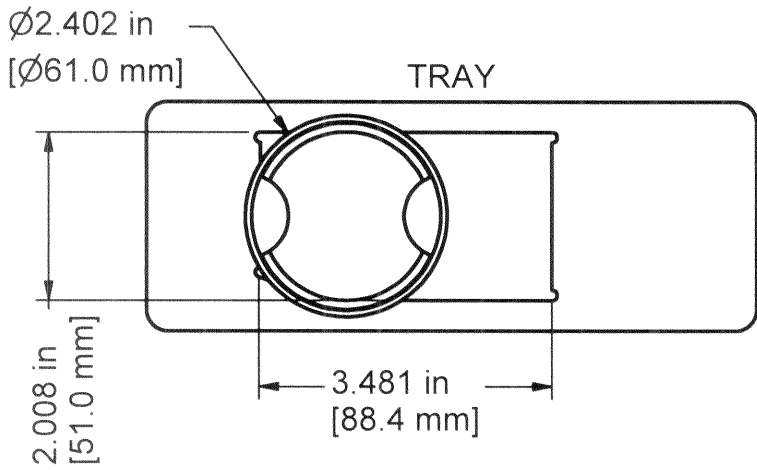

REVISION HISTORY			
REV	DESCRIPTION	DATE	BY
1	VALID	12-16-14	CMC

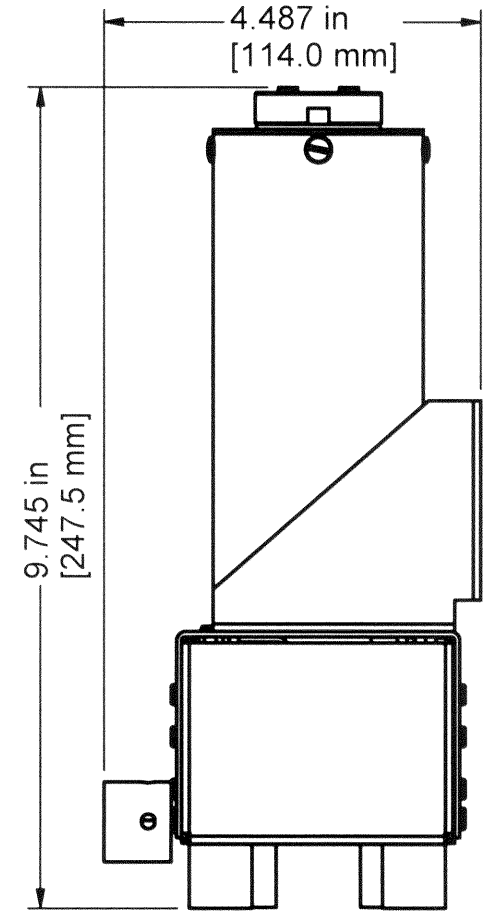
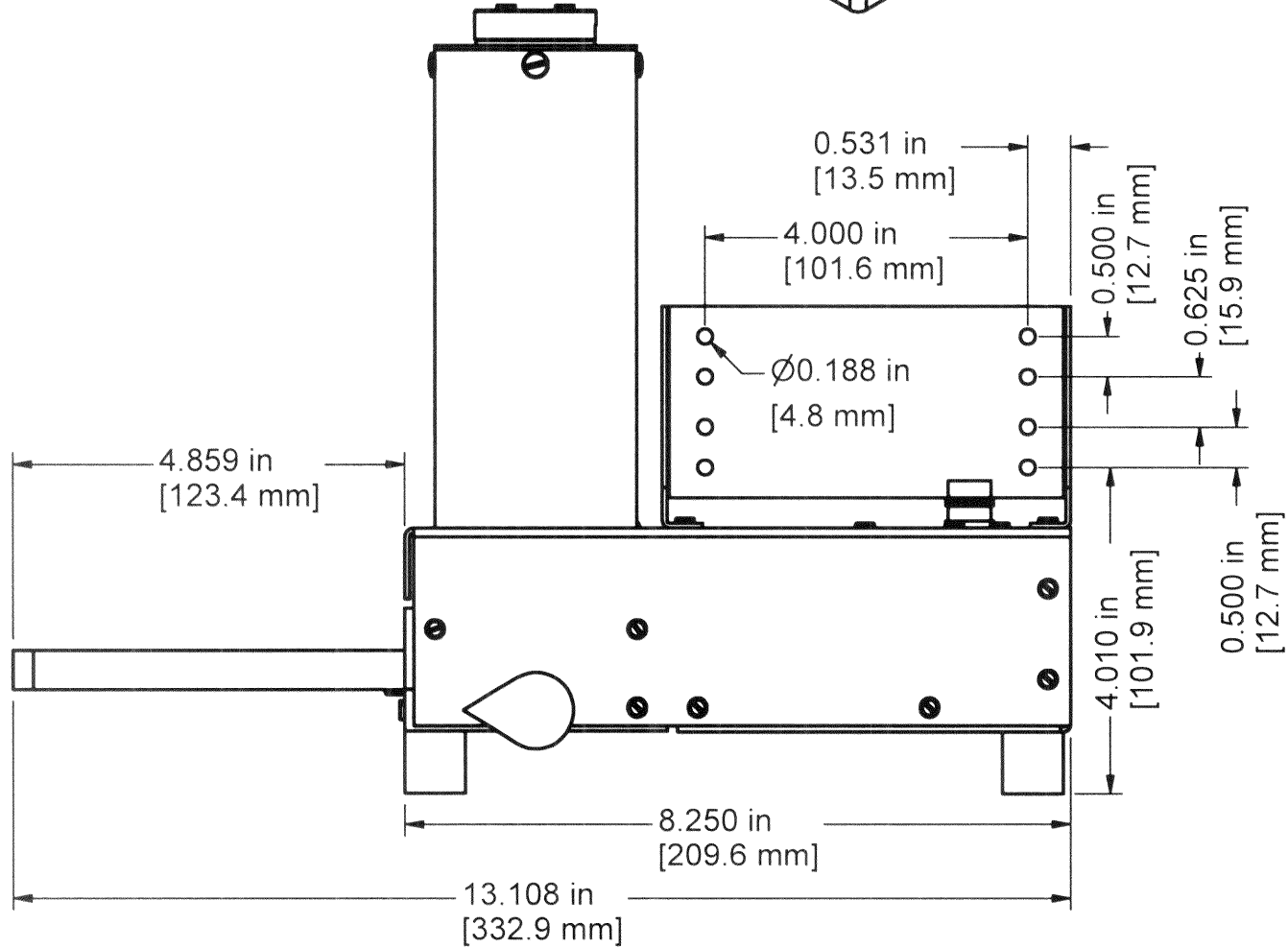

DWN	DATE	CHK	DATE	APP	DATE
JGW	2-11-20			<i>lw</i>	2-11-20
<b>DWG NUM: 4142-301</b>				SCALE: 7/16	
<b>TITLE M 43-10-10 OVERALL</b>					
LUDLUM MEASUREMENTS, INC. 501 OAK STREET SWEETWATER, TEXAS 79556			SERIES 142	SHEET 301	

**Model 43-10-1 Alpha/Beta Sample Counter**  
**April 2025**

**TABLE OF CONTENTS**

1. GENERAL-----	1
2. SPECIFICATIONS-----	1
3. OPERATING PROCEDURES -----	2
4. CALIBRATION -----	2
4.1 Counting Instrument-----	2
4.2 Operating Voltage -----	2
4.3 Calculating Efficiency -----	3
5. TROUBLESHOOTING -----	3
5.1 Zero or Very Low Counts-----	3
5.2 No Source Plateau-----	3
5.3 Excessive Background Count -----	3
PARTS LIST -----	4
Model 43-10-1 Alpha/Beta Sample Counter -----	4
Assembly View, Drawing 142 X 39B-----	4
Switch Filter Board, Drawing 142 X 58 -----	4
Voltage Divider Board Board, Drawing 435 X 964 -----	4
DRAWINGS AND DIAGRAMS -----	5

# Model 43-10-1 Alpha/Beta Sample Counter

## April 2025

### 1. GENERAL

---

The Model 43-10-1 is an Alpha-Beta Sample Counter capable of holding up to a 5.1 cm (2 in.) diameter filter or planchet. The sample drawer, when fully closed, strikes a microswitch to allow high voltage (HV) to be applied to the photomultiplier tube (PMT). The sample drawer is locked in the closed position by rotation of the slide lever mounted on the side of the instrument.

The detector is a 6.4 cm (2.5 in.) diameter “phoswich” with a 0.025 cm (0.010 in.) thick plastic scintillator coated with zinc sulfide (ZnS).

ZnS(Ag) is used for alpha radiation detection, and the plastic scintillation material is used for detection of beta radiation. The scintillation material is covered by 0.4 mg/cm<sup>2</sup> metalized polyester to reduce light response (excessive background). If simultaneous alpha-beta discrimination is desired, the counting instrument must have separate power supplies or threshold controls for each channel. The Ludlum Model 2929 Scaler, Model 2223, or Model 2224 instruments provide the necessary circuitry for simultaneous alpha-beta discrimination.

### 2. SPECIFICATIONS

---

**SCINTILLATOR MATERIAL:** ZnS disc; plastic 0.025 cm (0.010 in.) thick

**DETECTOR OPERATING VOLTAGE:** 500-1200 Vdc

**WINDOW:** 0.4 mg/cm<sup>2</sup>

**BACKGROUND:**  
≤ 80 cpm beta-gamma, ≤ 3 cpm alpha  
(in ambient background of 10μR/hr)

**CHANNEL CROSS TALK:** alpha in beta channel ≤ 10%; beta in alpha channel ≤ 1%

**EFFICIENCY (4π):** 37% for <sup>239</sup>Pu, 5% for <sup>14</sup>C, 27% for <sup>99</sup>Tc, 32% for <sup>230</sup>Th, 39% for <sup>238</sup>U, 29% for <sup>137</sup>Cs, 26% for <sup>99</sup>Sr/<sup>90</sup>Y

**HV SWITCH:** opening sample slide disables PMT high voltage

**PHOTOMULTIPLIER TUBE:** 5.1 cm (2 in.) diameter, 10 pin dynode structure

**SAMPLE SLIDE AND HOLDER:** sample cavity size is 56.9 mm (2.24 in.) diameter x 10.8 mm (0.428 in.) deep, with an insert cavity size of 50.8 mm (2.0 in.) diameter x 4.4 mm (0.175 in.) deep or 28.3 mm (1.115 in.) diameter x 4.4 mm (0.175 in.) deep.

**MAXIMUM SAMPLE SIZE:** 56.9 mm (2.24 in.) diameter x 10.8 mm (0.428 in.) deep

**CONSTRUCTION:** aluminum housing with beige powder coating

**SIZE:** 23.6 x 11.4 x 23.6 cm (9.3 x 4.5 x 9.3 in.) (H x W x L)

**WEIGHT:** 1.9 kg (4.1 lb)



**Model 43-10-1 Alpha/Beta Sample Counter**  
**April 2025**

### **3. OPERATING PROCEDURES**

---

Connect the Model 43-10-1 to the scaler counting instrument. The coax cable with "C" connectors carries both the signal and HV.

HV is applied to the PMT when the sample slide is pushed completely in, tripping the microswitch. Rotate the sample slide lever to the locked position, securing sample slide in the "ON" position.

Alpha background count is approximately less than or equal to 3 cpm.

Beta background count is approximately 60-100 cpm.

To check a radioactive sample, place sample on the appropriate side of the sample holder for the 2.5 or 5.1-centimeter (1 or 2 in.) filters. Do not allow the sample to extend above the top of the sample slide.

A background count should be taken after each source count to check for contamination on the sample holder or area within the O-ring.

### **4. CALIBRATION**

---

**CAUTION:** Do not tip sample counter over with sample holder in sample slide. The sample holder will tear the thin metalized polyester window, allowing light to scintillate the ZnS and cause excessive count in the beta channel.

For instruments with separate power supplies (fixed threshold), the alpha channel will operate at a lower voltage than the beta channel.

#### **4.1 Counting Instrument**

Calibrated scaler instrument  
HV range, nominally 800  $\pm$ 200 volts  
Nominal input sensitivity:  
alpha channel = 175 mV  
beta channel = 4 mV (with upper discriminator set at 50 mV)

#### **4.2 Operating Voltage**

1. Connect Model 43-10-1 to the counting instrument with proper cable.
2. Place a calibrated  $^{14}\text{C}$  source in the sample holder. Close and lock the sample

drawer.

3. Adjust the counting instrument HV until it receives at least 5% ( $4\pi$ ) efficiency.
4. Decrease HV by 25 volts.
5. Record the HV.
6. Record the  $^{14}\text{C}$  source count and beta crosstalk in the alpha channel.
7. Remove the  $^{14}\text{C}$  source and record the background count in the alpha and beta channels.
8. Place a calibrated  $^{239}\text{Pu}$  source in the sample holder. Close and lock the sample drawer.
9. Record the  $^{239}\text{Pu}$  source count and the alpha crosstalk in the beta channel.
10. Increase the HV by 25 volts.
11. Repeat steps 5-10 until one or more of the following conditions is met (assuming a 10  $\mu\text{R/hr}$  background exposure):
  - (a) beta background exceeds 80 cpm
  - (b) alpha background exceeds 3 cpm

**Model 43-10-1 Alpha/Beta Sample Counter  
April 2025**

- (c) alpha crosstalk in the beta channel exceeds 10%
  - (d) beta crosstalk in the alpha channel exceeds 1%
12. The operating voltage should be selected as a point where:
- (a)  $^{14}\text{C}$  efficiency ( $4\pi$ )  $\geq 5\%$
  - (b)  $^{239}\text{Pu}$  efficiency ( $4\pi$ )  $\geq 37\%$
  - (c) alpha crosstalk in beta channel less than or equal to 10%
  - (d) beta crosstalk in alpha channel less than or equal to 1%

### 4.3 Calculating Efficiency

1. NIST-traceable sources required.

2. Set HV as determined above.
3. Record a one-minute background and one-minute source count. Subtract the background count from the source count. Divide the net source count by the dpm value of the source, times 100 for  $4\pi$  efficiency.

**If the source value is listed in microcuries (activity):**

4. Convert the microcurie value to a dpm value by multiplying the microcurie value by  $2.22 \times 10^6$ . Calculate the  $4\pi$  efficiency as in the previous steps.

## 5. TROUBLESHOOTING

---

### 5.1 Zero or Very Low Counts

- Large light leak
- PMT malfunction
- Broken wire in tube socket
- Inoperative HV switch on sample counter or broken wire
- Counting instrument malfunction
- Source too far from scintillation material
- Cable malfunction

### 5.2 No Source Plateau

- Light leak, slide not sealed properly against true base
- Noisy PMT
- Noisy HV switch
- Poor PMT to scintillation, light pipe interface

### 5.3 Excessive Background Count

- Light leak
- PMT malfunction
- Cable malfunction
- Noisy HV switch
- Instrument contaminated

**Model 43-10-1 Alpha/Beta Sample Counter  
April 2025**

**PARTS LIST**

Ref. No.	Description	Part No.	Ref. No.	Description	Part No.
<b>Model 43-10-1 Alpha/Beta Sample Counter</b>			<b>Switch Filter Board, Drawing 142 X 58</b>		
UNIT	Completely Assembled 43-10-1 Detector	47-1305	BOARD	Assembled Switch Filter	5412-103
<b>Assembly View, Drawing 142 x 39B</b>			<ul style="list-style-type: none"> <li>▪ <b>CAPACITORS</b></li> </ul>		
* PM TUBE ASSY		01-5919	C1-C2	CAP-0.0056μF, 3kV, NPO	04-5522
* EJ444L-2.20 x .010 ZnS		01-5698	C3	CAP-0.0015μF, 3kV, C	04-5518
* METALIZED MYLAR		01-5143	<ul style="list-style-type: none"> <li>▪ <b>RESISTORS</b></li> </ul>		
* TUBE HOLDER/BASE		2142-002-02	R1-R2	RES-1MEG, 1/4W, 5%	10-7028
* CONNECTOR CAP		7142-014	<b>Voltage Divider Board, Drawing 435 X 964</b>		
* SAMPLE DRAWER			BOARD	Assembled Voltage Divider	5435-401
Model 43-10		7142-001-06	<ul style="list-style-type: none"> <li>▪ <b>CAPACITORS</b></li> </ul>		
* O-RING-2-229		16-8286	C1	0.01μF, 2kV, C	04-5722
* ACRYLIC DISC		7142-002-01	<ul style="list-style-type: none"> <li>▪ <b>RESISTORS</b></li> </ul>		
2 EA. SPACER STRIP .015		7142-002-03	R1-R12	4.75 MEG, 1/8W, 1%	12-7995
* ADAPTER PLATE		7142-003-01			
* CASE TOP		7142-004-03			
* CASE BOTTOM		7142-004-04			
* CAP GASKET		7142-017			
* BASE PLATE		7142-018			
* SHAFT		7142-019			
* LIFTER		7142-020			
* PIN		7142-021			
* O-RING-2-226		16-8270			
2 EA. SPACER STRIP .010		7142-232			
5 EA. 5.1 cm (2 in.) X-TAL FOAM PAD					
		7260-001-05			
10 EA. PLANCHETTE-2/X1/8 IN.		7525-371-3A			
* PLANCHET HOLDER		7142-001-07			
* BRACKET		7142-004-01			
* CAP		7142-004-02			
1 EA. SWITCH-BZ-2RD-A2		08-6538			
1 EA. KNOB-90 4 2G POINTER		08-6608			
1 EA. RECPT-UG706/U "C" LMI		4478-011			
4 EA. BUMPER PADS		21-9376			
2 EA. SPACERS		18-9043			

**DRAWINGS AND DIAGRAMS**

---

Model 43-10-1 Assembly View, Drawing 142 x 39B

Switch Filter Board, Drawing 142 x 58

Switch Filter Board Layout, Drawing 142 x 59 (2 sheets)

5.1 cm (2 in.) Voltage Divider Board, Drawing 435 x 964

5.1 cm (2 in.) Voltage Divider Board Layout, Drawing 435 x 965A (2 sheets)

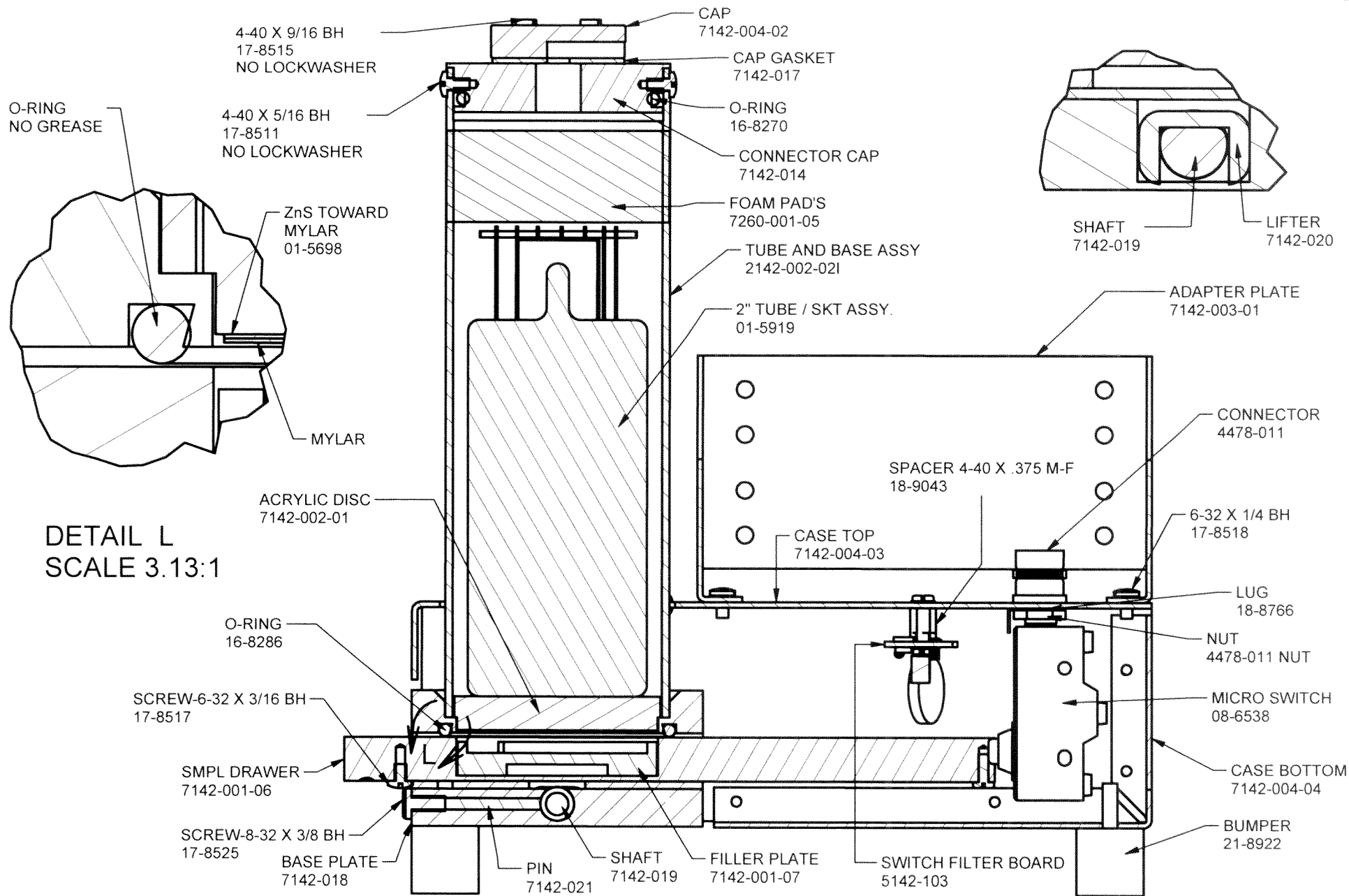

DETAIL L  
SCALE 3.13:1

REVISION HISTORY

REV	DESCRIPTION	DATE	BY
3	ECF # 1072	10/31/01	DSW
4	REDRAWN ON COMPUTER	05/23/2012	ADG
5	PLACED LOCKWASHERS	1/2/18	ZSZ
6	17-8518 WAS 17-8511	11/19/19	DLJ

DWN	DATE	CHK	DATE	APP	DATE
ABM	11/27/19			Jew	11-27-19
DWG NUM: 4142-076				SCALE: 1:1.5	
TITLE M 43-10-1					
LUDLUM MEASUREMENTS, INC. 901 OAK STREET SWEETWATER, TEXAS 79556			SERIES	SHEET	
			142	39B	

REVISIONS						
EFF	AUTHORITY	ZONE	LTR	DESCRIPTION	DATE	APPROVED

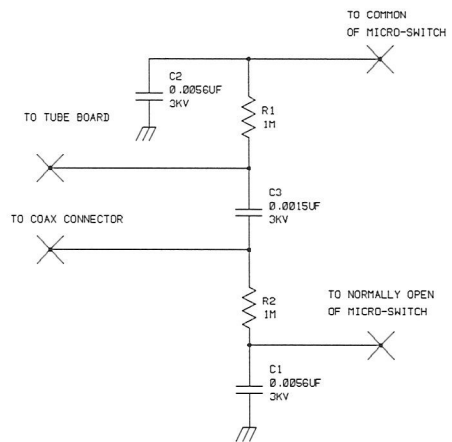

UPDATED		LUDLUM MEASUREMENTS INC.			
DR PW	10/20/92	TITLE: SWITCH FILTER BOARD			
CHK	CKB 27-JAN-99				
DSCN PW	10/20/92	BOARD# 5142-103			
APPD	ESS 11-6-01	SIZE	MODEL	SERIES	SHEET
NEXT HIGHER ASSY.	-	C	43-10	142	58
08:36:53	27-Jan-99	5B142103	SHEET 1 OF 1		

Top Layer (Scale 3:1)

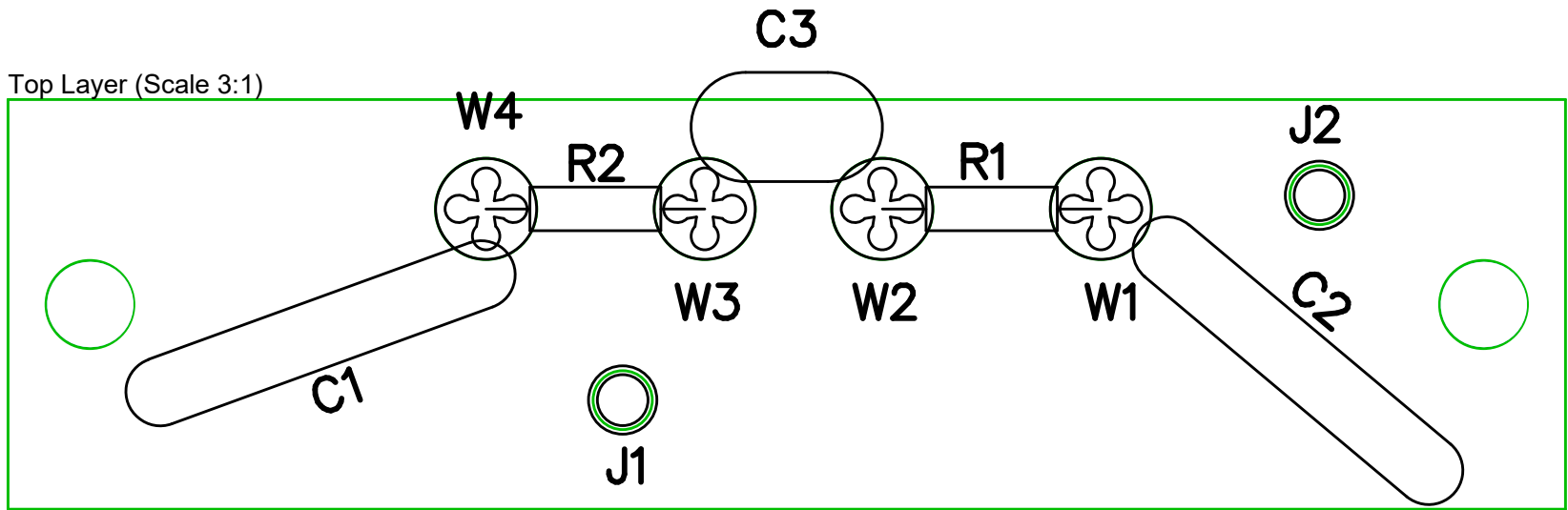

 <b>LUDLUM MEASUREMENTS</b>				
Part: 5142-103		Model: 43-10		
Desc: SWITCH FILTER BOARD				
Design: PW	Date: 10/20/1992		Rev:	1
Drawn: PAB	Date: 10/9/2024	SHEET	SERIES	SHEET
Apr: JMC	Date: 10/9/2024	1 of 3	142	59
W:\Projects\LM\43-10\5142-103\Rev1				

A

B

C

D

Bottom Layer (Scale 3:1)

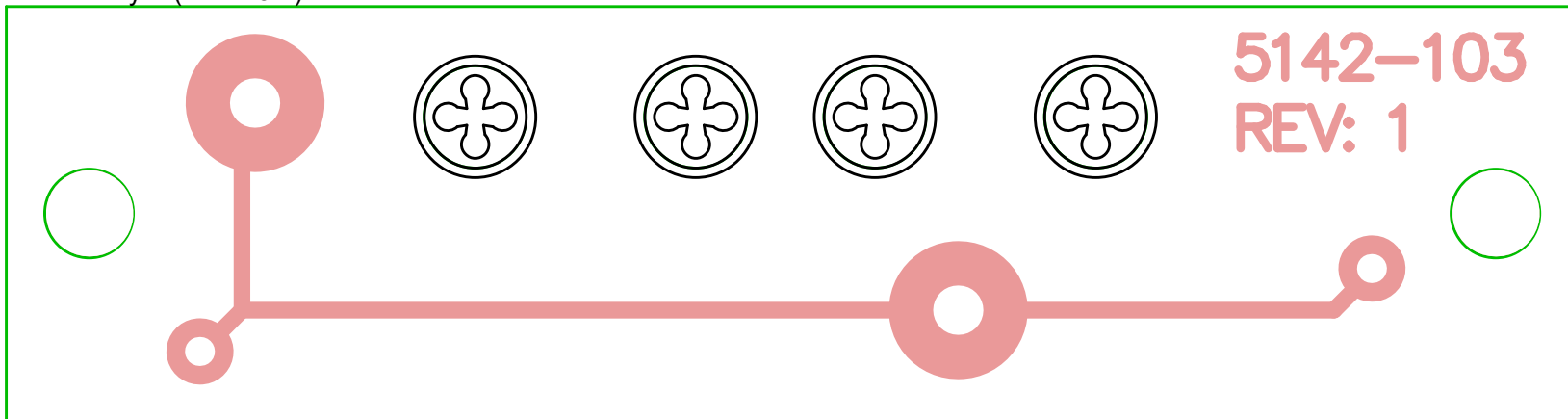

5142-103  
REV: 1

 <b>LUDLUM MEASUREMENTS</b>				
Part: 5142-103		Model: 43-10		
Desc: SWITCH FILTER BOARD				
Design: PW	Date: 10/20/1992		Rev:	1
Drawn: PAB	Date: 10/9/2024	SHEET	SERIES	SHEET
		2 of 3	142	59
W:\Projects\LM\43-10\5142-103\Rev1				



1

2

3

4

5

A

A

B

B

C

C

D

D

E

E

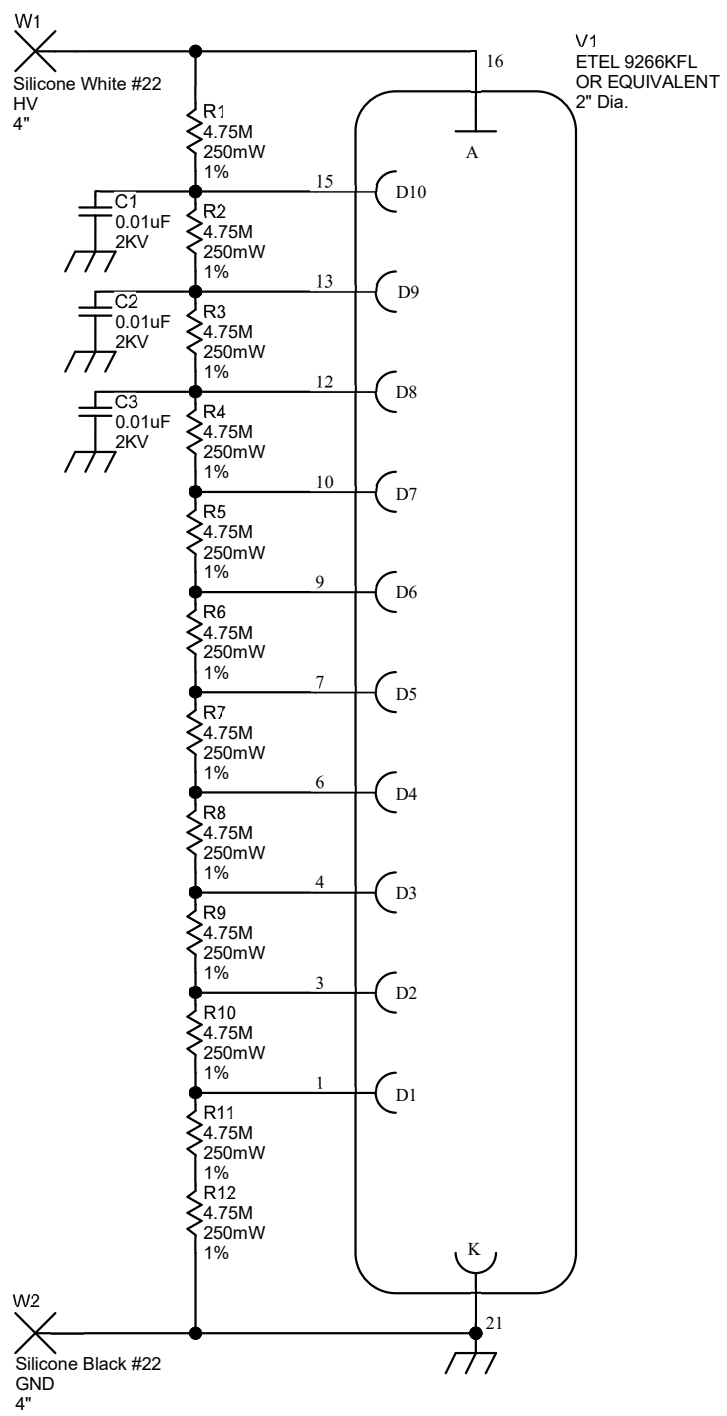

		PO Box 810 501 Oak Street Sweetwater, Texas 79556 U.S.A. 1-800-622-0828		
		<b>Drawn:</b> PAB <b>Design:</b> RSS	11/1/2024 05/07/2012	<b>Title:</b> VOLTAGE DIVIDER <b>Model:</b> VARIOUS <b>Board#:</b> 5435-401
<b>Approve:</b> JMC	11/1/2024	<b>Sheet:</b> 1 of 1	<b>Series:</b>	<b>Sheet:</b>
<b>Print Date:</b> 11/1/2024 3:55:57 PM		<b>Rev:</b> 2	435	964
<small>W:\Projects\LM\VoltageDividers\5435-401\Rev2\435401R2P1.SchDoc</small>				

1

2

3

4

5

A

B

C

D

Top Layer (Scale 3:1)

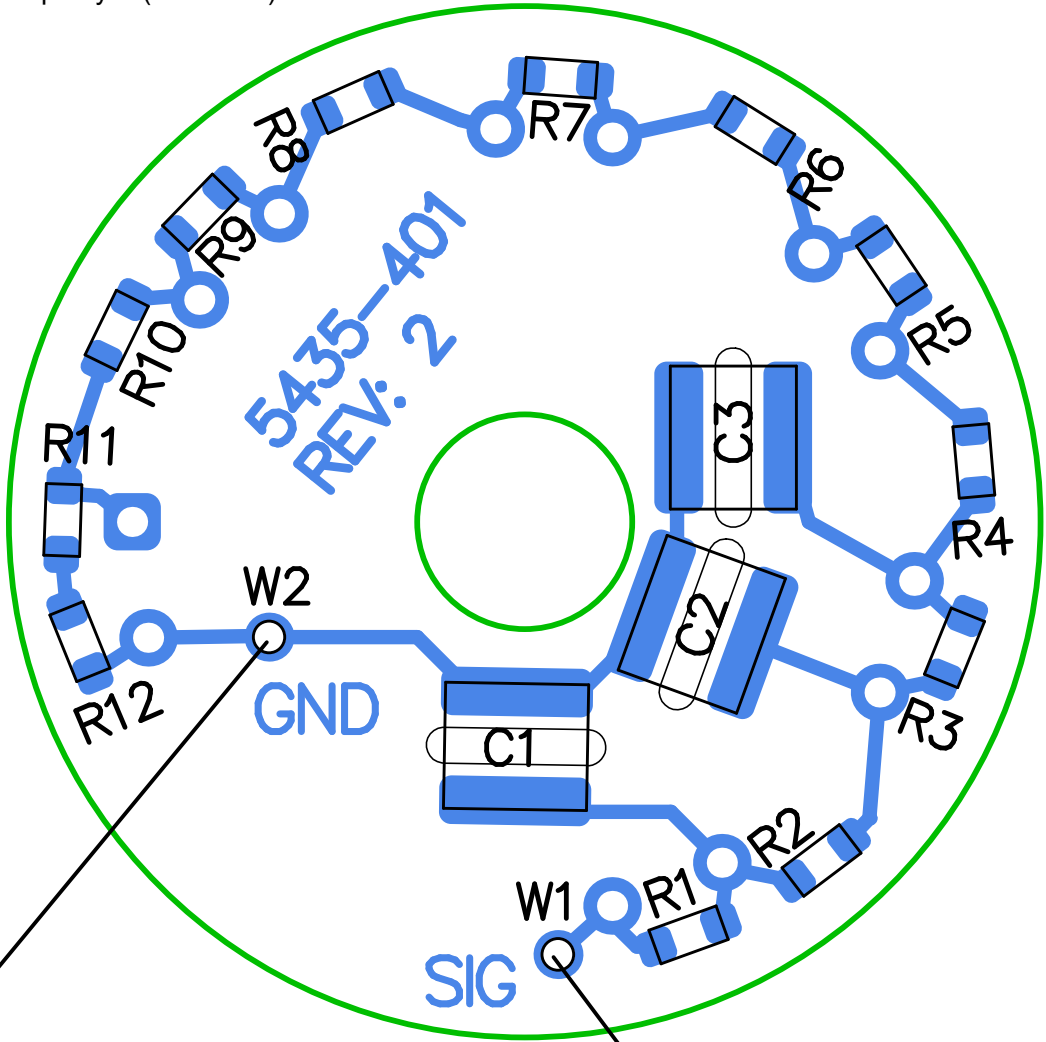

4" BLACK WIRE

4" WHITE WIRE

 <b>LUDLUM MEASUREMENTS</b>				
Part: 5435-401		Model: VARIOUS		
Desc: VOLTAGE DIVIDER				
Design: RSS	Date: 5/07/2012	Rev:	2	
Drawn: PAB	Date: 11/1/2024	SHEET	SERIES	SHEET
Apr: JMC	Date: 11/1/2024	1 of 3	435	965A
\freedom\pcb\Projects\LM\VoltageDividers\5435-401\Rev2				

A

B

C

D

A

B

C

D

Bottom Layer (Scale 3:1)

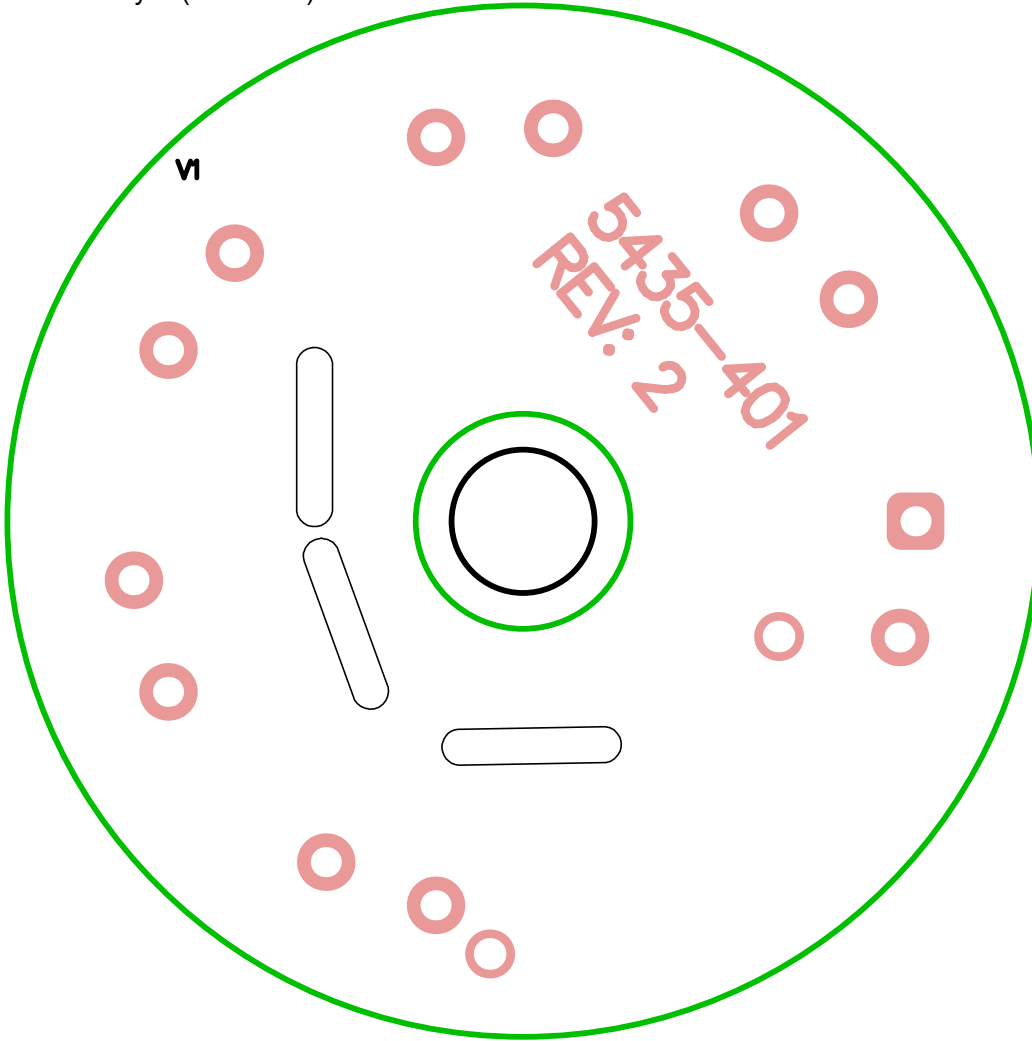

 <b>LUDLUM MEASUREMENTS</b>				
Part: 5435-401		Model: VARIOUS		
Desc: VOLTAGE DIVIDER				
Design: RSS	Date: 5/07/2012	Rev:	2	
Drawn: PAB	Date: 11/1/2024	SHEET	SERIES	SHEET
		2 of 3	435	965A
\freedom\pcb\Projects\LMI\VoltageDividers\5435-401\Rev2				

A

B

C

D

1

2

3

4

5

6

1

2

3

4

5

6