

**LUDLUM MODEL 52
PORTABLE PORTAL MONITOR**

**November 2011
Serial No. 175872 and Succeeding
Serial Numbers**

**LUDLUM MODEL 52
PORTABLE PORTAL MONITOR**

**November 2011
Serial No. 175872 and Succeeding
Serial Numbers**



LUDLUM MEASUREMENTS, INC
501 OAK STREET, P.O. BOX 810
SWEETWATER, TEXAS 79556
325-235-5494, FAX: 325-235-4672

STATEMENT OF WARRANTY

Ludlum Measurements, Inc. warrants the products covered in this manual to be free of defects due to workmanship, material, and design for a period of twelve months from the date of delivery. The calibration of a product is warranted to be within its specified accuracy limits at the time of shipment. In the event of instrument failure, notify Ludlum Measurements to determine if repair, recalibration, or replacement is required.

This warranty excludes the replacement of photomultiplier tubes, G-M and proportional tubes, and scintillation crystals which are broken due to excessive physical abuse or used for purposes other than intended.

There are no warranties, express or implied, including without limitation any implied warranty of merchantability or fitness, which extend beyond the description of the face there of. If the product does not perform as warranted herein, purchaser's sole remedy shall be repair or replacement, at the option of Ludlum Measurements. In no event will Ludlum Measurements be liable for damages, lost revenue, lost wages, or any other incidental or consequential damages, arising from the purchase, use, or inability to use product.

RETURN OF GOODS TO MANUFACTURER

If equipment needs to be returned to Ludlum Measurements, Inc. for repair or calibration, please send to the address below. All shipments should include documentation containing return shipping address, customer name, telephone number, description of service requested, and all other necessary information. Your cooperation will expedite the return of your equipment.

**LUDLUM MEASUREMENTS, INC.
ATTN: REPAIR DEPARTMENT
501 OAK STREET
SWEETWATER, TX 79556**

**800-622-0828 325-235-5494
FAX 325-235-4672**

**Model 52 Portable Portal Monitor
November 2011**

TABLE OF CONTENTS

1.	GENERAL	1
2.	ASSEMBLY INSTRUCTIONS	1
	2.1 Packing Instructions	3
3.	USER OPERATION	4
	3.1. Operational Check	4
	3.2. Personnel Monitoring	4
4.	SPECIFICATIONS	7
5.	DESCRIPTION OF CONTROLS AND FUNCTIONS	7
6.	PARAMETERS AND FUNCTIONS	9
	6.1 Alarm Menu Parameters	9
	6.2 Time Menu Parameters	9
	6.3 Volume Menu Parameters	9
	6.4 Background Menu Parameters	9
	6.5 Person Counter	10
	6.6 Water Resistant Sleeve	10
	6.7 RS-232 Port	10
7.	SETUP OPERATION	12
	7.1 Setup Menu	12
	7.1.1 Setup Alarm Menu	12
	7.1.2 Setup Background Menu	12
	7.1.3 Setup Time Menu	14
	7.1.4 Setup Volume Menu	14
	7.1.5 Password Menu	15
	7.2. Read Menu	15
	7.2.1 Read Alarms Menu	15
	7.2.2 Read Time Menu	15
	7.2.3 Read Volume Menu	16
	7.3 Counts Menu	16
8.	CALIBRATION PROCEDURE	16
	8.1 General	16
	8.2 Equipment Required	16
	8.3 Calibration Procedure	16
PARTS LIST		18
	Model 52 Portable Portal Monitor	18
	Main Board, Drawing 215 x 60	18
	AMP/HVPS Board, Drawing 215 x 82	19
	LED Display, Drawing 215 X 63	20
	LED Display Driver, Drawing 420 X 4	20
	Wiring Diagram, Drawing 215 X 116	20
DRAWINGS AND DIAGRAMS		21

Model 52 Portable Portal Monitor

November 2011

1. GENERAL

The Model 52 Portal Monitor is used for Beta/Gamma personnel contamination monitoring and meets the FEMA standard for Emergency Response Portal Monitoring (FEMA-REP-21). It is designed to be disassembled for ease of transportation and storage, and can be assembled in five minutes or less without tools. All parameters are stored in non-volatile memory, which requires no battery backup. These parameters allow easy operation with minimal setup by minimally trained personnel. The parameters are pre-set at the factory to detect a 1 μCi ^{137}Cs beta window source in a 10 $\mu\text{R/hr}$ background field, in accordance with the FEMA standard. The Model 52 can be powered by 120 Vac or 6 “D” cell batteries. 220 Vac-powered units are available as a special order.

The instrument has a “person-counter” integrated into the electronics that increments by 1 every time a count is completed. It is a four-digit number normally displayed on the LCD display, next to the “READY” message. It also has an RS-232 port that can be used to print out parameter setpoints, background counts, and counts above background.

The portal frame incorporates an array of 18 GM (Geiger-Mueller) detectors positioned around the frame and base. Fourteen GM pancake detectors are located in the frame for monitoring the head and body. Four cylindrical GM detectors are utilized in the base for monitoring the feet.

The electronics are microprocessor-based for ease of setup and reliability. Individual LEDs (Light Emitting Diodes) mounted in the frame and also on the electronics front panel indicate the specific alarm location. LEDs in the front panel indicate count cycle status. Audible signals accompany the LEDs for additional indication. Detector counts, background, and all parameters may be viewed on the LCD display. All setup is accomplished via pushbuttons on the electronics assembly.

The Model 52 incorporates a summing alarm in addition to the individual channel alarms. This increases the system sensitivity to widespread contamination. If two or more channels have a noticeable increase in counts, but do not exceed their alarm threshold, the sum of their counts could exceed the summing alarm.

The Model 52 also has background update and subtract capabilities. The instrument will take a background count and subtract it from the current count. This function helps compensate for fluctuations in background. Background subtract can be turned on or off, and the background count time, and the background interval time are adjustable. The operator can force the instrument to stop and take a background count at a different interval if desired.

The alarm volume is adjustable via the keypad on the front panel. For further explanation of parameters and their functions, see Section 6.

2. ASSEMBLY INSTRUCTIONS

SEE FIGURE 1 – MODEL 52 ASSEMBLY DRAWING ON PAGE 2

This section gives instructions on how to assemble the Model 52 and get it ready for use.

The Model 52 comes in a container that can be used for shipping and storage. The pieces and quantities that make up the system are:

- 1 - Base
- 1 - R1 (Right #1) Section
- 1 - R2 Section
- 1 - R3 Section
- 1 - L1 Section
- 1 - L2 Section
- 1 - L3 Section
- 1 - Top Section
- 1 - Electronics Section
- 1 - Power Cord
- 1 - Remote electronics extension cable (optional).

Unpack the container and inventory to ensure that all pieces are present.

The Model 52 can be assembled without tools. All connections are made with latches. To connect a latch, lift up the bottom tab, hook the top cross bar into the hook on the piece that you are attaching, and push tab back down until it snaps into place.

CAUTION: Exercise care when unlatching pieces, as the latches can spring open violently.

To unlatch, lift up the tab and unhook the top cross bar.

- Set the **Base** on the ground with the screens over the foot detectors facing up.

**Model 52 Portable Portal Monitor
November 2011**

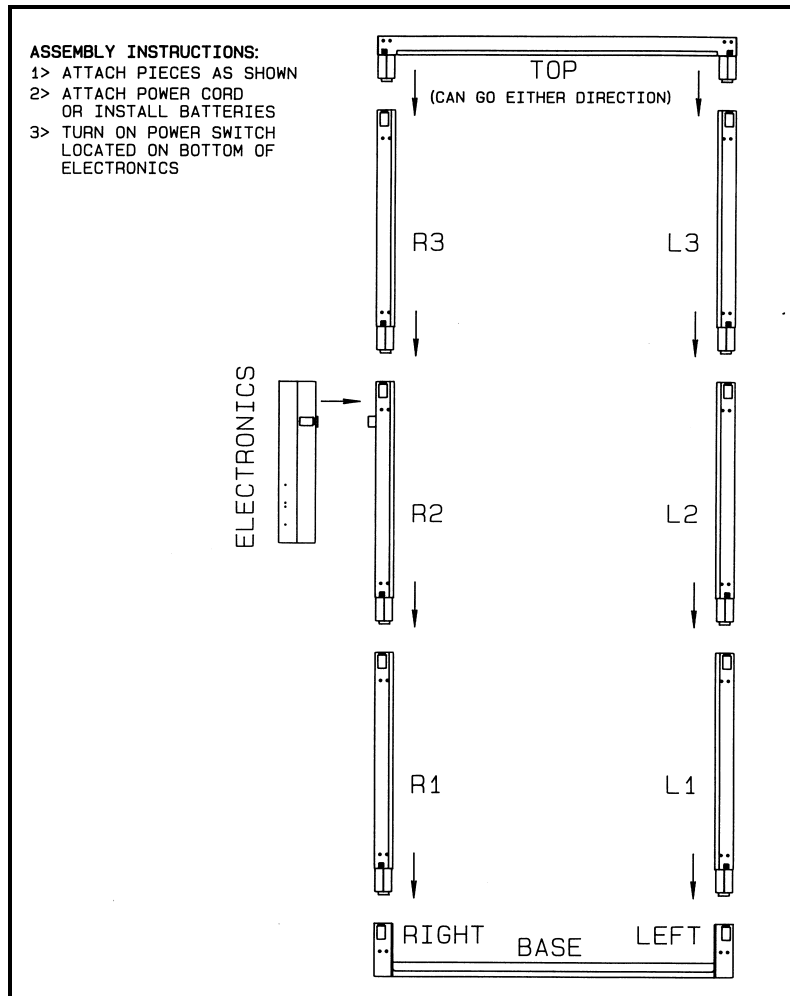

Figure 1 – Model 52 Assembly Drawing

- Insert the male end of section **R1** into the female side bracket of the base marked **RIGHT** and attach the latches. The detector screens must be facing toward the middle of the portal.
- Insert the male end of section **R2** into female end of section **R1** and attach the latches.
- Repeat the process for the rest of the side sections (**R3** through **L3**).
- Insert the **TOP** into the tops of the side sections and attach the latches. The top can be installed in either direction. It does not matter which end goes to the right.
- Plug the **ELECTRONICS** section onto the back of section **R2** with the LEDs facing up. Make sure that the pin in the back of R2 goes into the hole on the electronics. Then attach the latches. If you are using the optional Remote Electronics Extension Cable, plug it between R2 and the electronics. Place the electronics wherever necessary.
- If you have line voltage available, plug the **POWER CORD** into the connector on the bottom of the electronics marked INPUT. If not, install 6 “D” cell batteries into the battery compartment. The power cord and batteries may both be installed at the same time, but the Model 52 does not charge the batteries.
- **Turn on** the **POWER** switch located on the bottom of the electronics and allow the instrument to finish updating. If the pre-programmed settings are acceptable, it is ready for use. Proceed to User Operation, Section 3. If the settings need to be changed or checked, proceed to Parameter Setup, Section 7.

Model 52 Portable Portal Monitor
November 2011

2.1 Packing Instructions

1. LAY THE 3/8" THICK FOAM AGAINST THE INNER SIDES OF THE CASE.
2. LAY TOP INTO CASE ON ITS SIDE AS SHOWN.
3. PLACE A SECTION BESIDE THE TOP WITH 1/4" FOAM IN BETWEEN.
4. PLACE OTHER SECTIONS IN PLACE WITH FOAM IN BETWEEN.
5. LEAVE ELECTRONICS ATTACHED TO SECTION R2 AND PLACE INTO CASE.
6. LAY 1" THICK PIECE OF FOAM WITH NOTCHES IN END ON TOP OF SECTIONS.
7. TURN BASE ASSEMBLY UPSIDE DOWN AND PLACE IN CASE.

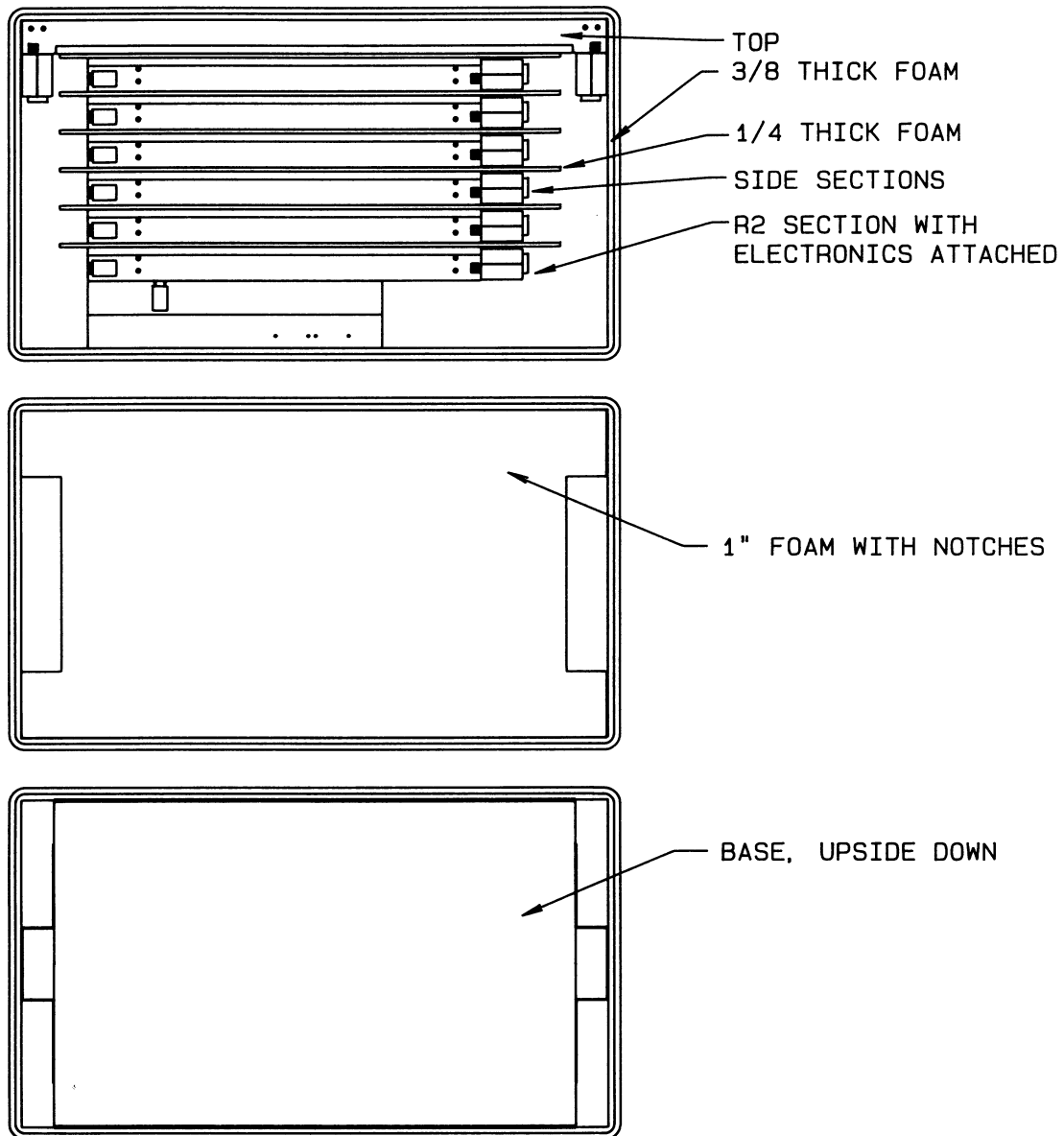

Figure 2 – Model 52 Packing Instructions

Model 52 Portable Portal Monitor

November 2011

3. USER OPERATION

This section gives instructions on how to use the instrument to monitor a person for radiation contamination. It assumes that the unit has been assembled and turned on. If this is not the case, refer to Assembly Instructions, Section 2. For information on Parameter Setup, see Section 7. The front panel and top and bottom views are on pages 5 and 6.

3.1 Operational Check

To ensure that the Model 52 is functioning correctly, an operational check should be performed on a routine basis. This check verifies that the instrument is turned on, that the settings are appropriate, and that the system alarms when the detectors are exposed to excess radiation (above background level). Ludlum Measurements suggests that this operational check be performed once per day or at the beginning of each work period. As long as the system passes the operational check, no calibration or other checks are necessary. If the response or any function of the Model 52 should change, the instrument should be checked and brought into compliance with the manufacturer's original specifications.

- Check each of the eight sections for sensitivity to radiation. There are 3 sections on each side, one at the top, and one on the floor (base plate). Using the check source supplied with the instrument (^{137}Cs , approximately 1 μCi), hold the source as described on the instrument's Certificate of Calibration, with the active side of the source turned toward the panel to be tested.
- Activate the counter by pressing on the base plate. When the audible beep sounds, the six-second count time commences. Keep the source in place with pressure on the base plate until the alarm sounds. The visual alarms on the frame and control panel relevant to that panel should also illuminate. Remove the source and the pressure on the base plate to allow the unit to reset. If any of the appropriate alarms do not activate before the end of the six-second count (indicated by another audible beep), the instrument requires a check to the manufacturer's specifications and possible repair.
- Repeat alarm checks for all sections. For the base plate, perform the check on each side, holding the source as described on the

instrument's Certificate of Calibration.

- To also provide assurance that the instrument meets the FEMA emergency response criteria prior to operation of this portal, do the following: Pass the 1 μCi ^{137}Cs check source through the center of the portal at several points between 0.5 and 5 feet from the floor of the portal, and verify that the alarm is triggered each time. If the portal does not alarm each time, the user may need to adjust the count time, the alarm points, or move the portal to a location with lower background radiation.

3.2 Personnel Monitoring

A count starts when someone steps onto the base plate. A count can only be started when the system is in the **READY** mode. **You must exit out of any setup menus before a count can be taken.**

Prior to operation, the monitor must be allowed to update the background count if background time is not set to zero. This mandatory update occurs just after power-up and then after expiration of the background update interval timer. New background count data is compared to the low and high-background set points that have been programmed into the unit. If the set points have been exceeded, a **HI BACKGROUND** or **LO BACKGROUND** alarm is given and the unit returns to updating background. The instrument will continue to update the background until the alarm condition has been corrected, i.e. the background goes down, failed detectors are repaired, or the parameters have been changed.

To check someone for radiation contamination, follow the steps below:

- The green **READY** light must be lit in order to use the instrument. An orange **UPDATING** light may be on, indicating that a standby update is taking place. When the **UPDATING** light is on, the system should not be used and all people to be checked should remain at least 0.91 m (3 ft) away until the **READY** light comes back on.
- The subject steps onto the base plate and positions feet on the foot detector screens. The green **COUNTING** light will come on.
- The yellow **INCOMPLETE** light will turn

Model 52 Portable Portal Monitor

October 2010

on if the subject steps off of the base plate before the count is complete.

- When the count is complete, the green **CHECK OK** light or one or more of the red alarm lights will turn on. If there is an alarm, the alarm LEDs on the top of the electronics and the LEDs on the portal frame will indicate the location of the alarm.

- The subject then steps off the instrument.

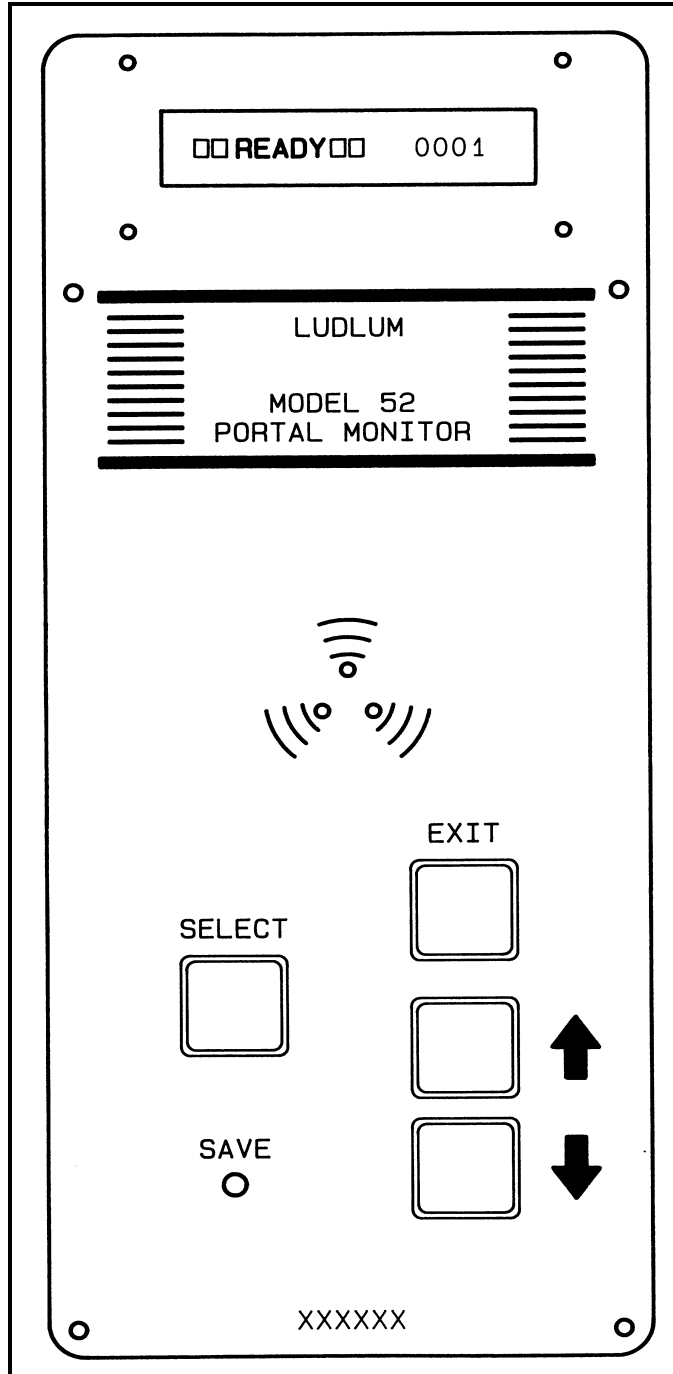

Figure 3 – Model 52 Front Panel Drawing

Model 52 Portable Portal Monitor
October 2010

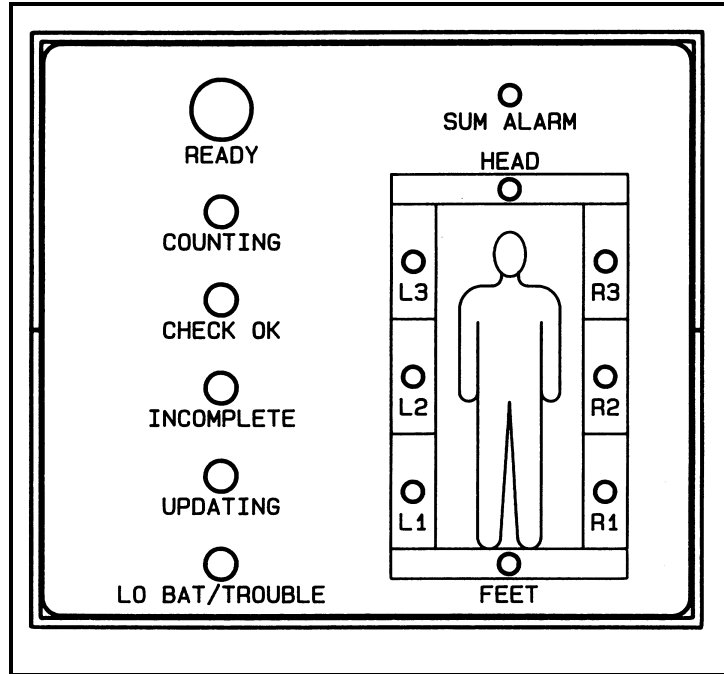

Figure 4 – Model 52 Electronics Top View

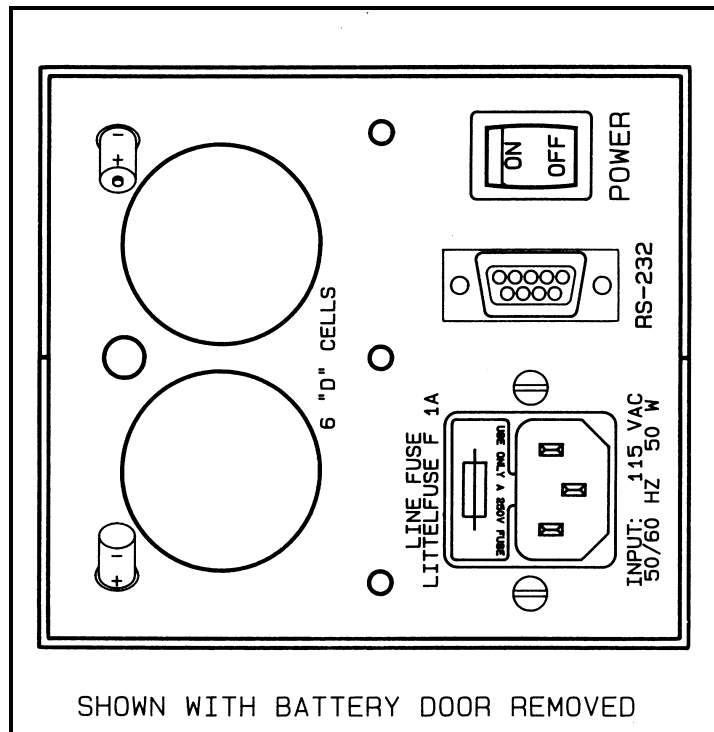

Figure 5 – Model 52 Electronics Bottom View

Model 52 Portable Portal Monitor

October 2010

4. SPECIFICATIONS

FUSE: Littelfuse F-1A, 1 amp, 5 x 20 mm, 250 volt

COUNTING CAPACITY: 9999 counts per minute

SENSITIVITY: 80 mV

COUNT TIME: adjustable from 1 to 60 seconds

ALARM HOLD TIME: adjustable from 1 to 99 seconds

BACKGROUND UPDATE INTERVAL: automatic, adjustable from 0-99 minutes, 0 = OFF

BACKGROUND COUNT TIME: adjustable from 0-99 seconds, 0 = OFF

FORCE BACKGROUND UPDATE INTERVAL TIME: adjustable from 0 to 99 minutes, 0 = OFF.

PERSON COUNTING CAPACITY: 9999 people before rolling back to zero.

SETUP PASSWORD: four-digit numeric password that, if enabled, must be entered before having access to the setup menu.

AUDIO: unimorph speaker with keypad adjustable volume

POWER: 95-135 Vac (178-238 VAC available), 50/60 Hz, 50 watts maximum or six (6) "D" cell batteries. Battery life is approximately 80 hours in a non-alarm condition.

OUTSIDE DIMENSIONS: 206 x 102 x 63 cm (81 x 40.3 x 24.8 in.) (H x W x D)

INSIDE DIMENSIONS: 194 x 81.3 cm (76.5 x 32 in.)

WEIGHT: 29.5 kg (65 lb) (38.6 kg [85 lb] including case)

5. DESCRIPTION OF CONTROLS AND FUNCTIONS

FRONT PANEL - (See Figure 3 on page 5)

- **READOUT:** LCD, 1-line, 16-character alphanumeric display. It normally displays "□ □ READY □ □" "XXXX," with the "XXXX" being the number of people who have been checked by the instrument. It will display other messages, depending upon the operational status of the instrument. Counts, alarms, and other information can be displayed by following the instructions in Section 7.
- **EXIT Key:** moves back one menu selection.
- **Increment (Up Arrow "↑") Button:** moves up one line in the current menu.
WITHIN PARAMETER SETUP: A digit increments by 1. An on/off parameter toggles to the other state.
- **Decrement (Down Arrow "↓") Button:** moves down 1 line in the current menu.
WITHIN PARAMETER SETUP: A digit decrements by 1. An on/off parameter toggles to the other state.
- **SELECT Key:** selects the current menu displayed on the readout. When setting parameters, it activates the digits so that they can be changed.
- **SAVE Key:** recessed pushbutton that saves all parameters to non-volatile memory. This button can only be operated by inserting a small screwdriver or pin through the hole. All of the microprocessor RAM is transferred to EEPROM memory when this button is pushed. Any changes made to variables only change the current microprocessor RAM. If the Model 52 is turned off prior to saving changes, the changes are lost. To save parameter changes, press the **SAVE** button before turning the Model 52 off. Upon power-up, the EEPROM memory is loaded into the microprocessor. If the **SAVE** key is pressed while turning the instrument on, the Model 52 is loaded with a set of default parameters.

Model 52 Portable Portal Monitor

October 2010

The parameters that are set are:

Default Value

Count time	6 sec
Background Count Time	60 sec
Update Interval	5 min
Force Background	30 min
Hold Time	6 sec
Alarm Volume	255
Password On/Off	OFF
Password	0000

Alarms

Left	200
Right	200
Head	200
Feet	250
Sum	450

Background Alarms

Left Low/High	25/1000
Right Low/High	25/1000
Head Low/High	25/1000
Feet Low/High	50/1000

LEDs (top of electronics) - (See Figure 4 on page 6 for LED layout)

- **READY LED:** normally lit prior to any interrogation. System is ready to take a count.
- **COUNTING LED:** indicates that a count is in progress. Stepping off of the base plate prior to expiration of the count time will cause this light to go off and the **INCOMPLETE LED** to come on. When the count is complete, the **CHECK OK** or one of the alarm LEDs will activate.
- **CHECK OK LED:** indicates that a count has been completed and no alarms were sensed. This LED will stay on until the subject steps off of the base plate or for 2 seconds, whichever is longest.
- **INCOMPLETE LED:** indicates that a count was in progress and the subject stepped off of the base plate before the count was complete. The **Incomplete LED** stays on for the alarm hold time or until the subject steps back onto the base plate. An incomplete resets the count time. If no one steps back onto the base plate during the

incomplete time, then the Model 52 goes back to the ready state, lighting the **READY LED**.

- **LO BAT / TROUBLE LED:** indicates that the batteries are weak and must be replaced. It can also indicate that the system has detected a high or low-background condition. If there is a background problem, the **UPDATING LED** will also be lit and the LCD display will have a message displayed. If the batteries are weak, the **LO BAT/TROUBLE LED** will be the only LED illuminated. Battery condition will not be indicated when the system is connected to line voltage.
- **SUM ALARM, HEAD, etc. LEDs:** indicate which channel has alarmed during a count. These light as soon as an alarm is sensed; when the count is complete, the **CHECK OK** will not light, the audio will stay on for the alarm hold time, and then the Model 52 goes back to the ready state, lighting the **READY LED**. The **SUM ALARM** is an alarm that adds all the channels together to determine if there is widespread contamination. If several channels have a high count but not high enough to exceed their individual alarm threshold, then the sum of the channels could exceed the sum alarm threshold.

BOTTOM OF ELECTRONICS - (See Figure 5 on page 6)

- **Power On/Off:** switch to turn instrument on and off. Switches both line voltage and batteries.
- **Line Fuse:** fuse to limit current from AC outlet. The fuse is a Littelfuse F 1A or equivalent.
- **INPUT:** line voltage input, 115 Vac, 50/60 Hz, 50 W.
- **6 "D" CELLS (underneath door):** compartment for batteries. Holds 3 "D" cell batteries per side. Install batteries as shown by diagram above holes.
- **RS-232:** necessary for instrument to be connected to a printer or a computer.

Model 52 Portable Portal Monitor

October 2010

6. PARAMETERS AND FUNCTIONS

This section lists the different parameters of the Model 52 and their functions.

All counts, alarms, and other settings are in **COUNTS PER MINUTE**. The instrument makes the necessary calculations to convert the count time setting into **counts per minute**.

The **READ** menu accesses the same parameters and in the same way as the **SETUP** menu. **However, no parameters may be changed in the READ menu.**

The **COUNTS** menu shows the accumulated counts in each channel.

6.1 Alarm Menu Parameters

ALARMS - This parameter sets the number of **counts per minute** that it takes to set off an alarm. If background subtract is turned on, the alarm will be the number of counts above background. If it is turned off, the alarm will be the number of gross counts. All channels must have their alarms individually set. An alarm can be turned off by setting it to zero.

LO BACKGROUND ALARM - This parameter sets the number of **counts per minute** that the background should not fall below in normal operation. If background falls below this level, a LO BACKGROUND alarm will be signified by a message on the LCD and illumination of the UPDATING light and the LO BAT/TROUBLE light. This alarm indicates if a detector has failed or is not connected. This alarm will also indicate if the ambient background has gone down. All channels must have their LO BKGND Alarms individually set, and each can be turned off by setting it to zero.

HI BACKGROUND ALARM - This alarm is the opposite of the LO BACKGROUND alarm. This alarm will indicate if background radiation has increased or if a detector has failed. All channels must be set individually and each can be turned off by setting to zero.

6.2 Time Menu Parameters

COUNT TIME - This parameter sets the length of time in **seconds** that the instrument will accumulate counts before determining if a subject is contaminated. Its range is 1 to 60 seconds.

ALARM HOLD TIME - This sets the length of time in seconds that visual and audible alarm signals will stay on before the instrument goes back to the READY mode. All alarms and INCOMPLETE are controlled by this timer.

6.3 Volume Menu Parameters

ALARM VOLUME - This sets the volume of the audible alarm signal. Setting range is from 1 (lowest) to 255 (loudest). Audio can be turned off by setting to zero.

6.4 Background Menu Parameters

BACKGROUND SUBTRACT ON/OFF - This allows you to turn the background subtract function on or off.

BACKGROUND COUNT TIME - This sets the length of time in seconds the instrument will accumulate counts to determine background. The instrument takes the last three background counts and averages them to determine background. The setting range is from 0 to 99 seconds. If BACKGROUND COUNT TIME is set to zero, no background will ever be taken. This includes the initial background taken at startup.

BACKGROUND INTERVAL - This sets the length of time in minutes that the instrument will wait before taking another background count. After the time has elapsed, the instrument will attempt to take a background count. The setting range is from 0 to 99 minutes. Zero is off. If something interrupts it during the count (someone steps on the base plate, changes a parameter, etc.), the count is aborted and the instrument will try again as soon as it returns to the READY mode. During heavy usage, it is possible that the instrument may never be able to complete a background count. After a background count has been taken, the INTERVAL and FORCE INTERVAL timers are reset. If BACKGROUND INTERVAL is set to zero, the background will never be updated after the initial startup background.

FORCE BACKGROUND INTERVAL - This sets the length of time in minutes the instrument will wait before it shuts down

Model 52 Portable Portal Monitor October 2010

operation and forces you to allow it to take a new background count. The setting range is from 0 to 99 minutes. During heavy usage, the normal background interval may not be able to take a background count. The FORCE interval will cause the instrument to shut down until it has had a chance to update background. This time interval must always be larger than the BACKGROUND INTERVAL or the COUNT TIME. After a background count has been taken, the INTERVAL and FORCE INTERVAL timers are reset.

6.5 Person Counter

The Person Counter is built into the Model 52 electronics so that the operator can keep track of the number of people who have been surveyed by the instrument. It is also printed out with the counts to help keep track of which person was contaminated. The counter is displayed on the LCD along with the READY message. The counter can be reset by turning the instrument off and then back on.

6.6 Water Resistant Sleeve

In order to provide a degree of protection against rain, a water resistant sleeve is available for the instrument. To install, simply slide the sleeve over the bottom R1 section before installing the rest of the sections. After all detector sections have been installed, stretch the sleeve over all sections. Cut a hole in the sleeve over the connector for the electronics. Slide a short piece of sleeving over the electronics, and cut a hole over that connector as well. Fold the sleeve over the top of the electronics, and then attach the electronics to the detector section. Proceed with operation of the instrument.

6.6 RS-232 Port

The RS-232 port allows the instrument to be connected to a printer or a computer so that a record can be kept of the activity of the instrument

When connected to a printer - When the instrument is first turned on, the printer will print the parameter settings. From then on, when a count is complete, the printer will print out the person number, the background counts, and the number of counts above background for all channels. Check OK or Alarm will be printed with an asterisk beside any channel that has exceeded its alarm set point. See the examples below.

When connected to a computer - The instrument will send the same data to a computer that it sends to a printer (see above). The optional computer software will display the data on the screen and allow it to be saved to a file.

See following page for examples of RS-232 port printouts.

Model 52 Portable Portal Monitor
October 2010

**The Model 52 RS-232 port operates at 9600 baud, 8 data bits, 1 stop bit, no parity (9600,8,N,1).
Example printout from the RS-232 port after power-on.**

LUDLUM MEASUREMENTS, INC.
MODEL 52 PORTAL MONITOR
PARAMETER LIST

COUNT TIME = 006 SEC
BACKGROUND COUNT TIME = 060 SEC
UPDATE INTERVAL = 005 MIN
FORCE BACKGROUND = 060 MIN
HOLD TIME = 006 SEC
ALARM VOLUME = 255

SECTION	ALARM POINT	LO COUNT	HI BKGND
L1	0200	0000	1000
L2	0200	0000	1000
L3	0200	0000	1000
R1	0200	0000	1000
R2	0200	0000	1000
R3	0200	0000	1000
FEET	0250	0000	1000
HEAD	0200	0000	1000
SUM	0450		

ALL COUNTS IN CPM.

Example printout from the RS-232 port after a complete count.

PERSON # 0001
CHECK OK

SECTION	BACKGROUND	COUNT ABOVE BKGND	ALARM
L1	0079	0000	NO
L2	0087	0000	NO
L3	0071	0009	NO
R1	0085	0000	NO
R2	0089	0051	NO
R3	0072	0000	NO
FEET	0252	0000	NO
HEAD	0072	0000	NO
SUM	0807	0060	NO

ALL COUNTS IN CPM.

Model 52 Portable Portal Monitor

October 2010

7. SETUP OPERATION

SEE FIGURE 6 on page 13 for menu diagram.

This section gives instructions on how to use the keys to set up the instrument. Examples of keystroke sequences are given for several parameters. Use the menu tree diagram and similar keystrokes to access other parameters. For information on using the instrument to make a radiation check, see Section 3.

To move from one level of the menu tree to a sub-level, press the SELECT key. To move up one level, press the EXIT key. To step through the different items on one level, use the UP or DOWN ARROW KEYS. The SELECT key also moves from one digit to the next when setting parameters.

To reset all parameters to their default settings, hold down the SAVE key while turning on the instrument.

All parameters are listed in the following order: L1, L2, L3, R1, R2, R3, FEET, HEAD, and SUM.

When you press the SELECT key from READY Mode, you have the following selections.

- 1 - Setup Menu
- 2 - Read Menu
- 3 - View Counts Menu

7.1 Setup Menu

The setup menu has four choices:

- 1- Setup ALARMS MENU
- 2- Setup BACKGROUND MENU
- 3- Setup TIME MENU
- 4- Setup VOLUME MENU
- 5- Setup PASSWORD MENU

To change a parameter, access the variable of interest through the setup menus using the SELECT and increment/decrement “↑/↓” keys. Press the SELECT key to change the parameter. The cursor becomes visible and blinks on the variable to change. On multiple digit variables, press the SELECT key to access the next digit.

7.1.1 Setup Alarms Menu

The SETUP ALARMS menu allows changes to be made to the count alarms for each of the Individual Alarm channels.

To access the SETUP ALARM menu:

- Turn the instrument ON. Wait for READY to display on the LCD.
- Press SELECT once to select the setup menu. SETUP menu appears.
- Press SELECT once to execute the setup menu. ALARMS menu appears.
- Press SELECT once to execute the alarms menu. L1 ALARM XXXX appears where XXXX is a four-digit number between 0 and 9999. To access other alarm channels, use the increment (“↑” or decrement “↓”) keys.
- To change the current setting, press SELECT to activate the first digit. Use increment/decrement “↑/↓” to change the first digit as desired. Press SELECT to activate the second digit. Use increment/decrement “↑/↓” to change the second digit as needed. Repeat for the other digits. Press SELECT to temporarily save the settings.
- Repeat the above step to change the other alarm channels as desired.
- Press the EXIT key to exit back to the ALARMS menu.

NOTE: Press the SAVE key in order to put parameters in non-volatile memory before powering down.

7.1.2 Setup Background Menu

Access the SETUP menu:

- Ensure READY displayed on LCD.
- Press SELECT once to select the setup menu. SETUP menu appears.
- Press SELECT once to execute the setup menu. ALARMS menu appears.
- Press decrement “↓” once to advance to the BACKGROUND MENU.

Model 52 Portable Portal Monitor October 2010

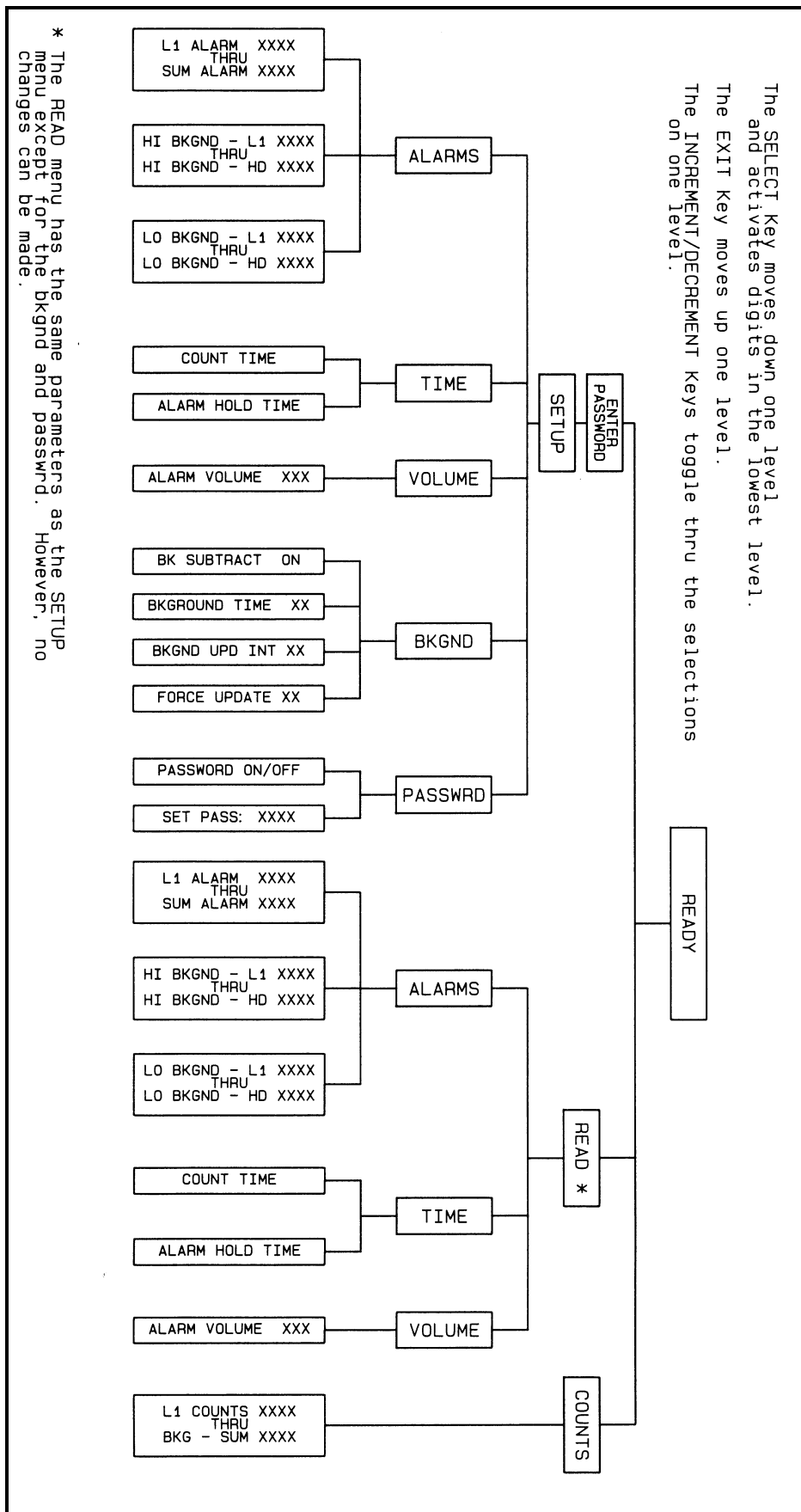

Figure 6 – Model 52 Menu Tree Diagram

Model 52 Portable Portal Monitor

October 2010

- Press SELECT once to activate the BACKGROUND menu.
- Press SELECT and use either the increment or decrement (“↑” or “↓”) key to toggle the back-ground subtract feature ON or OFF as desired. This will normally be left in the ON position. Activate and exit the ON/OFF prompt by pressing the SELECT key one last time.
- Press the decrement “↓” key to select the BKGROUND TIME.
- **Note:** This number must be less than or equal to the FORCE UPDATE and BKGND UPD INT parameter as set above.
- Press the decrement “↓” key to select the BKGND UPD INT timer. Save and exit this item by pressing the SELECT key one time. **Note:** This parameter must be greater than or equal to the BKGROUND TIME parameter and less than or equal to the FORCE UPDATE parameter.
- Press the decrement “↓” key to move to the FORCE UPDATE interval timer. Press the SELECT key to edit this timer as desired. The FORCE INTERVAL must always be larger than the BKGND UPD INT and the BKGND TIME. Save and exit this menu item by pressing the SELECT key one last time.

7.1.3 Setup Time Menu

This menu sets the count time and alarm hold time. The alarm hold time also applies to the Incomplete LED.

To access the SETUP TIME menu:

- Ensure READY displayed on the LCD.
- Press SELECT once to select the setup menu. SETUP menu appears.
- Press SELECT once to execute the setup menu. ALARMS menu appears.
- Press the decrement “↓” key twice. TIME menu appears.
- Press SELECT once to execute the setup time menu. “COUNT TIME XX” appears. The “XX” is a number between 1 and 60.
- Press SELECT to activate the first digit.

Use increment/decrement “↑/↓” keys to change the first digit. Press SELECT to activate the second digit. Use increment/decrement “↑/↓” to change the second digit. Press SELECT to temporarily save parameter.

- Use increment/decrement “↑/↓” to change to the next setting.
- Press the EXIT key to exit back to the TIME menu.

NOTE: Press the SAVE key in order to store parameters in non-volatile memory prior to power down.

7.1.4 Setup Volume Menu

The volume menu sets the alarm volume. The Model 52 emits a beeping sound after various events (mode change, parameter change, etc.). This beeping volume is always at the maximum and is not adjustable.

To access the SETUP VOLUME menu:

- Ensure “READY” is displayed on LCD.
- Press SELECT once to select the setup menu. SETUP menu appears.
- Press decrement “↓” three times to get to the VOLUME MENU.
- Press SELECT once to execute the setup volume menu. “ALARM VOLUME XXX” appears. The “XXX” is a number between 1 and 255. This variable sets from 001 (lowest) to 255 (loudest). A value of 000 mutes the audio alarm volume. Any audio alarm uses this volume set point. The beep audio is not affected by this setting.
- Press SELECT to activate the first digit. Use increment/decrement “↑/↓” to change the first digit. Press SELECT to activate the second digit. Use increment/decrement “↑/↓” to change the second digit. Repeat for third digit. Press SELECT to save.
- Press the EXIT key to exit back to the VOLUME menu.

NOTE: Press the SAVE key in order to store parameters in non-volatile memory prior to power-down.

Model 52 Portable Portal Monitor

October 2010

7.1.5 Password Menu

This menu sets the password and whether the password is ON or OFF.

To access the PASSWORD menu:

- Ensure “READY” is displayed on LCD.
- Press SELECT once to select the setup menu. SETUP menu appears.
- Press SELECT once to execute the setup menu. ALARMS menu appears.
- Press the increment or decrement (“↑” or “↓”) keys until the PASSWORD menu appears.
- Press SELECT once to execute the password on/off menu. “PASSWORD: XXX” appears. The “XXX” is either ON or OFF.
- Press SELECT to change the password status. Use increment/decrement “↑/↓” to change to either ON or OFF. Press SELECT to temporarily save parameter.
- Use increment/decrement “↑/↓” to change to the next setting. “ENTER PASS: XXXX” appears.
- To reset the PASSWORD to 0000, hold down the SAVE key while turning on the instrument.
- Press SELECT to activate the first digit. Use increment/decrement “↑/↓” to change the first digit. Press SELECT to activate the second digit. Use increment/decrement “↑/↓” to change the second digit. Repeat for third and fourth digit. Press SELECT to save.
- Press the EXIT key to exit back to the TIME menu.

NOTE: Press the SAVE key in order to store parameters in non-volatile memory prior to power down.

7.2. Read Menu

The Read Menu has three choices:

- 1- Read Alarms Menu
- 2- Read Time Menu
- 3- Read Volume Menu

The read menu accesses the same menu structure as the Setup Menu. However, no variables may be changed from the read menu.

7.2.1 Read Alarms Menu

To access the READ ALARMS menu:

- Turn the instrument ON. Wait for “READY” to display on the LCD.
- Press SELECT once to select the setup menu. SETUP menu appears.
- Press increment “↑” key once. READ menu appears.
- Press SELECT once to execute the read menu. ALARMS menu appears.
- Press SELECT once to execute the alarms menu. “L1 ALARM “XXXX” appears.
- Use the increment/decrement “↑/↓” keys to change to the next alarm channel.
- Press the EXIT key to exit back to the ALARMS menu.

7.2.2 Read Time Menu

This menu reads all of the time parameters of the Model 52. The user cannot change these values from this menu.

To access the READ TIME menu:

- Turn instrument ON. Wait for “READY” to display on LCD.
- Press SELECT once to select the setup menu. SETUP menu appears.
- Press decrement “↓” key once. READ menu appears.
- Press SELECT once to execute the Read menu. ALARMS menu appears.

Model 52 Portable Portal Monitor

October 2010

- Press decrement “↓” key once. TIME menu appears.
- Press SELECT once to execute the time menu. “COUNT TIME XX” appears. The “XX” is a number between 0 and 99.
- Use the increment/decrement “↑/↓” keys to change to other time parameters.
- Press the EXIT key to exit back to the TIME menu.

7.2.3 Read Volume Menu

This menu reads all of the volume parameters of the Model 52. The user cannot change these values from this menu.

To access the READ VOLUME menu:

- Turn the instrument ON. Wait for “READY” to display on LCD.
- Press SELECT once to select the setup menu. SETUP menu appears.
- Press decrement “↓” key once. READ menu appears.

8. CALIBRATION PROCEDURE

8.1 General

The Model 52 is set for 80 mV sensitivity and 900 Vdc operation for GM type detectors.

8.2 Equipment Required

- Ludlum Model 500 Pulser or equal
- High-impedance voltmeter for high-voltage measurements (1000 megohm)
- 8 to 15 volt DC power supply
- Digital counter or oscilloscope for negative going 5 Vdc pulses

8.3 Calibration Procedure

Calibration of the Model 52 is accomplished by adjustments to the amplifier board located inside each detector section of the portal frame. Adjustments include threshold voltage level and the

- Press SELECT once to execute the read menu. ALARMS menu appears.
- Press decrement “↓” key twice. VOLUME menu appears.
- Press SELECT once to execute the time menu. “ALARM VOLUME XXX” appears. The “XXX” is a number between 0 and 255.
- Use the increment/decrement “↑/↓” keys to change to other parameters.
- Press the EXIT key to exit back to the VOLUME menu.

7.3 Counts Menu

The counts menu will display the counts for each channel, one channel at a time.

Use the increment/decrement “↑/↓” keys to change to the next channel.

high-voltage power supply setting. The design threshold level is 80 mV and operating high voltage is approximately 900 Vdc.

The amplifier board has two eight-position DIP switches. The switch in line with the 10 pin MTA is used to select the LED connection, and the switch in line with the 14-pin MTA is used to select the signal connection. To set the switches for the section that the board will be used in, close the corresponding channel as listed below and open all others:

L1 - SWITCH 1
L2 - SWITCH 2
L3 - SWITCH 3
R1 - SWITCH 4
R2 - SWITCH 5
R3 - SWITCH 6
FOOT - SWITCH 7
HEAD - SWITCH 8

Model 52 Portable Portal Monitor October 2010

- Connect the center conductor of a cable from the Model 500 Pulsar to one of the Teflon-insulated connector jacks and ground to the metal sockets. Apply power to the board by supplying +12 Vdc to Pin 13 of one of the 14 pin MTA connectors and ground to pin 14.

You may use a voltage from 8 to 15 volts on pin 13. Pin 1 of the connector is defined as the pin on the right as you face the pins with the white tab on the other side of the pins. Pin 1 goes to switch 1 on the dip switches

- Attach the counter or oscilloscope to one of pins 1 through 8 of the 14-pin MTA connectors, connected to a closed switch. Adjust pulser amplitude to negative 80 mV and vary R1123 (THS) until pulses just appear.
- Adjust R194 (HV ADJUST) for 900 Vdc at the Teflon-insulated connector jack.

Model 52 Portable Portal Monitor
October 2010

PARTS LIST

Ref. No.	Description	Part No.	Ref. No.	Description	Part No.
Model 52 Portable Portal Monitor			R403	10k	12-7839
<hr/>			R431	10k	12-7839
UNIT	Completely Assembled Model 52 Portable Portal Monitor	48-2471	R501	10k	12-7839
Main Board, Drawing 215 x 60			R502	10 MEG	12-7955
<hr/>			R503	73.2k	12-7895
BOARD	Completely Assembled Main Board	5215-087	R504	10k	12-7839
• CAPACITORS			R505	82.5k	12-7849
C101	68µF 6.3V	04-5654	R506	1M	12-7844
C201	68µF 6.3V	04-5654	R507	8.25k	12-7838
C211	0.1µF 50V	04-5663	R508	10k	12-7839
C231	0.01µF 50V	04-5664	R701	5 k TRIMMER	09-6918
C301	2700µF 35V	04-5621	R1310	100k	12-7834
C311, C312	27pF 100V	04-5658	• RESISTOR NETWORK		
C501	68µF 6.3V	04-5654	RN031	NETWORK-4.7 K	12-7918
C502	0.1µF 50V	04-5663	RN121	NETWORK-4.7K 8P SIP	12-7706
C503	10µF 20V	04-5655	RN331	NETWORK-4.7 K	12-7918
C504-C506	0.1µF 50V	04-5663	RN421	NETWORK-22 K	12-7917
C601	10µF 20V	04-5655	• SWITCHES		
C602	4.7µF 20V	04-5653	S111	92-851.342 ELEMENT	08-6726
C603	10µF 20V	04-5655	S121	92-851.342 ELEMENT	08-6726
C611	4.7µF 20V	04-5653	S211	92-851.342 ELEMENT	08-6726
C701	0.1µF 50V	04-5663	S221	92-851.342 ELEMENT	08-6726
C711	0.1µF 50V	04-5663	S321	92-851.342 ELEMENT	08-6726
• DIODES			• TRANSFORMERS		
CR101-CR103	CXSH-4 EB33	07-6358	T401	XFMR- M 177 AUDIO	4275-083
• TRANSISTORS			• INTEGRATED CIRCUITS		
Q211	MMBT4403LT1	05-5842	U121	22K DIP 14 PIN	12-7577
Q401	2N7002L	05-5840	U122	LTC1045CN	06-6371
Q402	MMBT4403LT1	05-5842	U131	TLC372ID	06-6290
Q501	MMBT3904T	05-5841	U211	X24C02S8I	06-6299
• RESISTORS			U231-U233	TLC372ID	06-6290
R031	4.75k	12-7858	U311	N87C51FA	06-6286
R111	100k	12-7834	U331	TLC372ID	06-6290
R131-R139	2.21k	12-7835	U421	CD74HC573M	06-6298
R211, R212	10k	12-7839	U431	N82C54	06-6309
R231	100k	12-7834	U501	LM358D	06-6312
R331	22.1k	12-7843	U502	LM285M-2.5	06-6291
R401	10k	12-7839	U511	CXK581000AM-70LL	06-6385
R402	10 OHM	12-7836	U531	N82C54	06-6309
			U601	MAX232CSE	06-6382
			U611	CD74HC138M	06-6339
			U612	CD74HC00M	06-6308
			U631	N82C54	06-6309
			U711	CD74HC08M	06-6313

**Model 52 Portable Portal Monitor
October 2010**

Ref. No.	Description	Part No.	Ref. No.	Description	Part No.
• VOLTAGE REGULATOR			• DIODES		
VR201	LT1129CQ-5	06-6372	CR118	1N4007	07-6274
			CR134	1N4148	07-6272
			CR173	1N4007	07-6274
			CR175, CR176	1N4007	07-6274
			CR225	1N4001	07-6268
• CRYSTALS			• TRANSISTORS		
Y311	6.144MHZ	01-5262	Q123	2N3904	05-5755
			Q133	MPSW01	05-5778
			Q230	2N3904	05-5755
			Q256	MPS6534	05-5763
• MISCELLANEOUS			• RESISTORS		
SOCKET	822276-1 44P	06-6293	R110	1 M	10-7028
5 EA.	92-960-0 MTG FLNGE	08-6727	R113, R114	1 M	10-7028
P14	CONN-640456-2	13-8073	R115	10k	10-7016
P15	CONN-640456-6	13-8095	R116	8.2k	10-7015
P16	CONN-640456-3	13-8081	R141	200 OHM	10-7006
P17	CONN-640456-5	13-8057	R144	1 G	12-7686
P18	CONN-640456-3	13-8081	R145	10k	10-7016
P19	CONN-1-540456-1	13-8059	R146	22k	10-7070
P20	CONN-1-640456-4	13-8141	R159	10k	10-7016
<u>AMP/HVPS Board, Drawing 215 x 82</u>			R160	1k	10-7009
BOARD	Completely Assembled AMP/HVPS Board	5215-130	R161	4.7k	10-7014
			R162	1k	10-7009
			R164, R165	100k	10-7023
			R170	1k	10-7009
			R178	432k	12-7689
			R179	100k	10-7023
			R180	10k	10-7016
			R217	22k	10-7070
			R218	100 OHM	10-7004
			R219	10k	12-7540
			R220	7.15k	12-7620
			R222	33k	10-7019
			R223	47k	10-7020
			R224	100k	10-7023
			R229	470k	10-7026
			R241	1 M	10-7028
			R242	100k TRIMMER	09-6829
			R244	1 M TRIMMER	09-6778
			R245	4.7k	10-7014
			R247	56 OHM	10-7096
			• SWITCHES		
			S252, S253	76SB08S DIP	08-6549

**Model 52 Portable Portal Monitor
October 2010**

Ref. No.	Description	Part No.	Ref. No.	Description	Part No.
<ul style="list-style-type: none"> INTEGRATED CIRCUITS 			<ul style="list-style-type: none"> RESISTORS 		
U181	TLC372I	06-6265	R148	200 OHM	10-7006
U186	CA3096	06-6023	R149-R151	10k	10-7016
U211	LM358	06-6024	<ul style="list-style-type: none"> RESISTOR NETWORK 		
U235	LM385Z-1.2	05-5808	RN142-R144	150 OHM DIP 16P	12-7741
<ul style="list-style-type: none"> VOLTAGE REGULATOR 			<ul style="list-style-type: none"> INTEGRATED CIRCUITS 		
VR236	LM78L05	05-5815	U140, U141	SN75512	06-6369
<ul style="list-style-type: none"> TRANSFORMERS 			<p align="center">Wiring Diagram, Drawing 215 X 116</p> <hr/> <ul style="list-style-type: none"> SWITCHES 		
T2	L8050	40-0902	S1	DM62J12S205PQ W/LE	08-6715
<ul style="list-style-type: none"> MISCELLANEOUS 			<ul style="list-style-type: none"> TRANSFORMER 		
DS257	E176 RED JUMBO	07-6362	T1	CFP302 115/230V	22-9908
P13-P15	CONN-1-640456-4 MTA-100	13-8141	<ul style="list-style-type: none"> CONNECTORS 		
P16-P18	CONN-1-640456-0 MTA-100	13-8066	J1	CONN-640440-6 MTA100	13-8047
P-19	CONN-640456-2 MTA-100	13-8073	J2	CONN-640442-3 MTA100	13-8135
*	RECEPTACLE (7 ea) Cloverleaf 011-6809	18-8771	J3	CONN-640442-2 MTA100	13-8178
<p align="center">LED Display, Drawing 215 X 63</p> <hr/>			J4, J11	CONN-640442-5 MTA100	13-8140
BOARD	Completely Assembled LED Display Board	5215-090	J5	CONN-1-640442-4 MTA100	13-8173
<ul style="list-style-type: none"> LEDS 			J6	CONN-640441-3 MTA100	13-8160
DS110	E118-RED	07-6308	J7	CONN-1-640442-1 MTA100	13-8137
DS111	E119-ORANGE	07-6343	J9	CONN-640442-7 MTA100	13-8172
DS112	E120-YELLOW	07-6309	J14	D RECPT-9 PIN	13-8003
DS113, DS114	E121-GREEN	07-6310	J15	CONN-1-640442-4 MTA100	13-8173
DS115	E178-GRN JUMBO	07-6364	<ul style="list-style-type: none"> MISCELLANEOUS 		
DS116-DS124	E112-RED	07-6390	DSO1	UNIMORPH	21-9251
<ul style="list-style-type: none"> CONNECTORS 			J13	AC RECEPTACLE	13-8427
P8	CONN-CJ50-36B-10	13-8730	<p align="center">LED Display Driver, Drawing 420 X 4</p> <hr/>		
P9	CONN-640456-7 MTA-100	13-8115	BOARD	Completely Assembled Display Driver Board	5420-005

**Model 52 Portable Portal Monitor
October 2010**

DRAWINGS AND DIAGRAMS

Main Board, Drawing (2 sheets), 215 X 60

Main Board Layout, Drawing 215 X 103

AMP/HVPS Board, Drawing 215 X 82

AMP/HVPS Board Layout, Drawing 215 X 83

LED Display, Drawing 215 X 63

LED Display Board Layout, Drawing (2 sheets), 215 X 104

LED Display Driver, Drawing 420 X 4

LED Driver Layout, Drawing 420 X 89

Wiring Diagram-Electronics, Drawing 215 X 116

REV	AUTHORITY	ZONE	LINE	DESCRIPTION	DATE	APPROVED

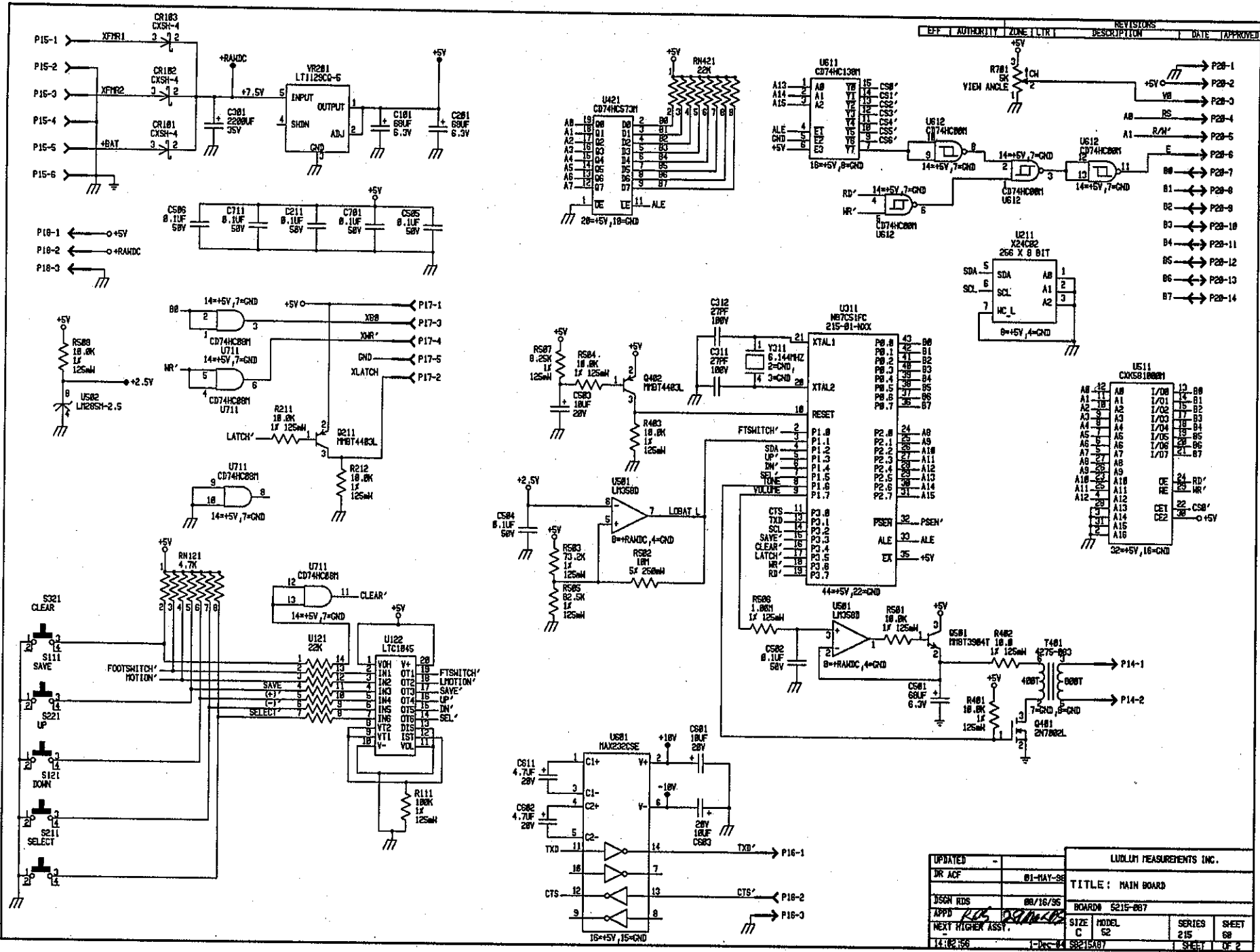

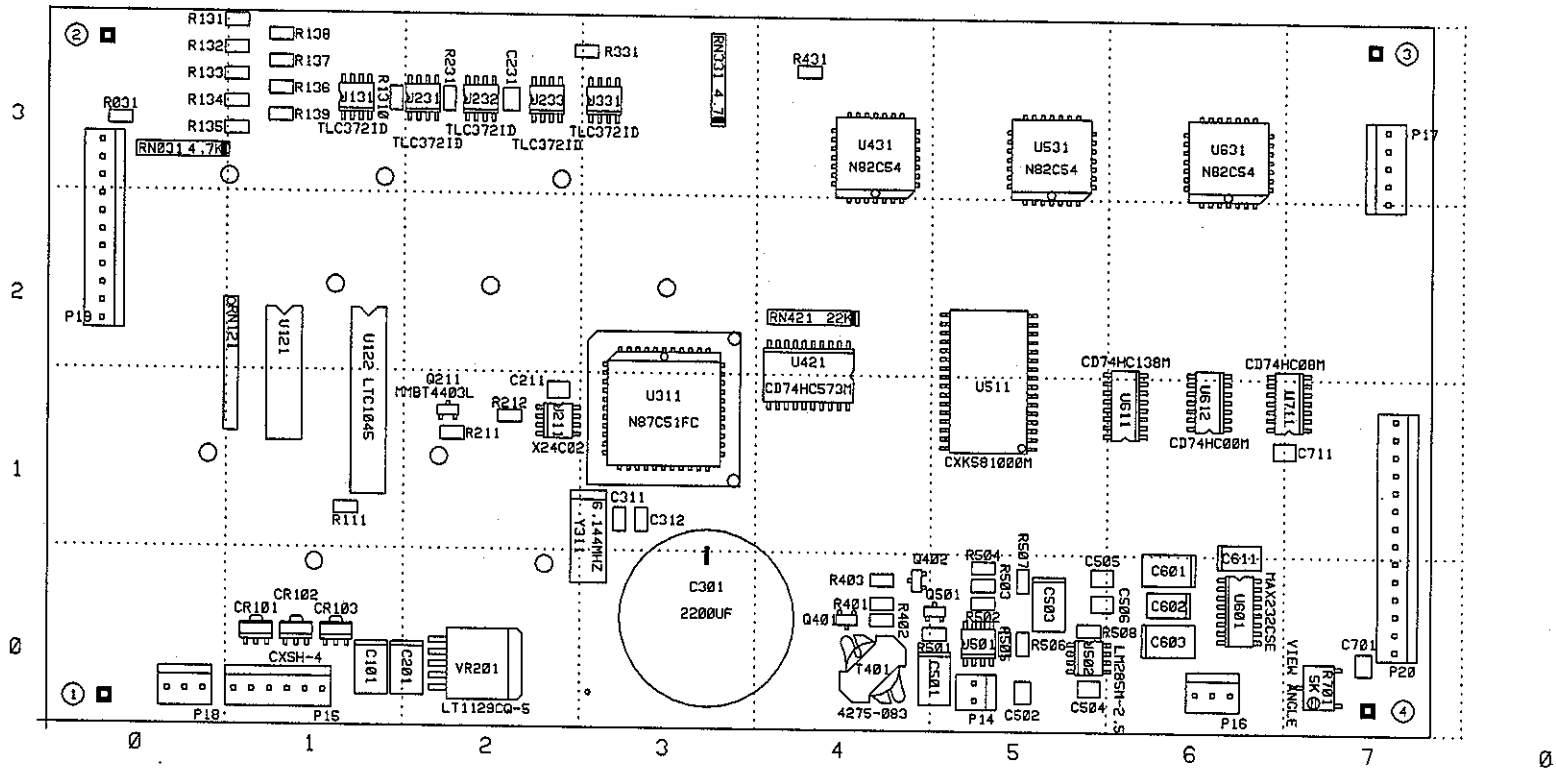

LUDLUM MEASUREMENTS INC. SHEETWATER, TX.				
DR	CKP	08/23/95	TITLE: MAIN BOARD	
		BOARD: 5215-007		
DSGN	RSS	08/18/95	MODEL: 52	
APP	<i>RIB ZAMMOS</i>			FILENAME: 8S215007
COMPONENT	SOLDER	16:25:16	23-Nov-04	
OUTLINE	OUTLINE	1.0	215	103

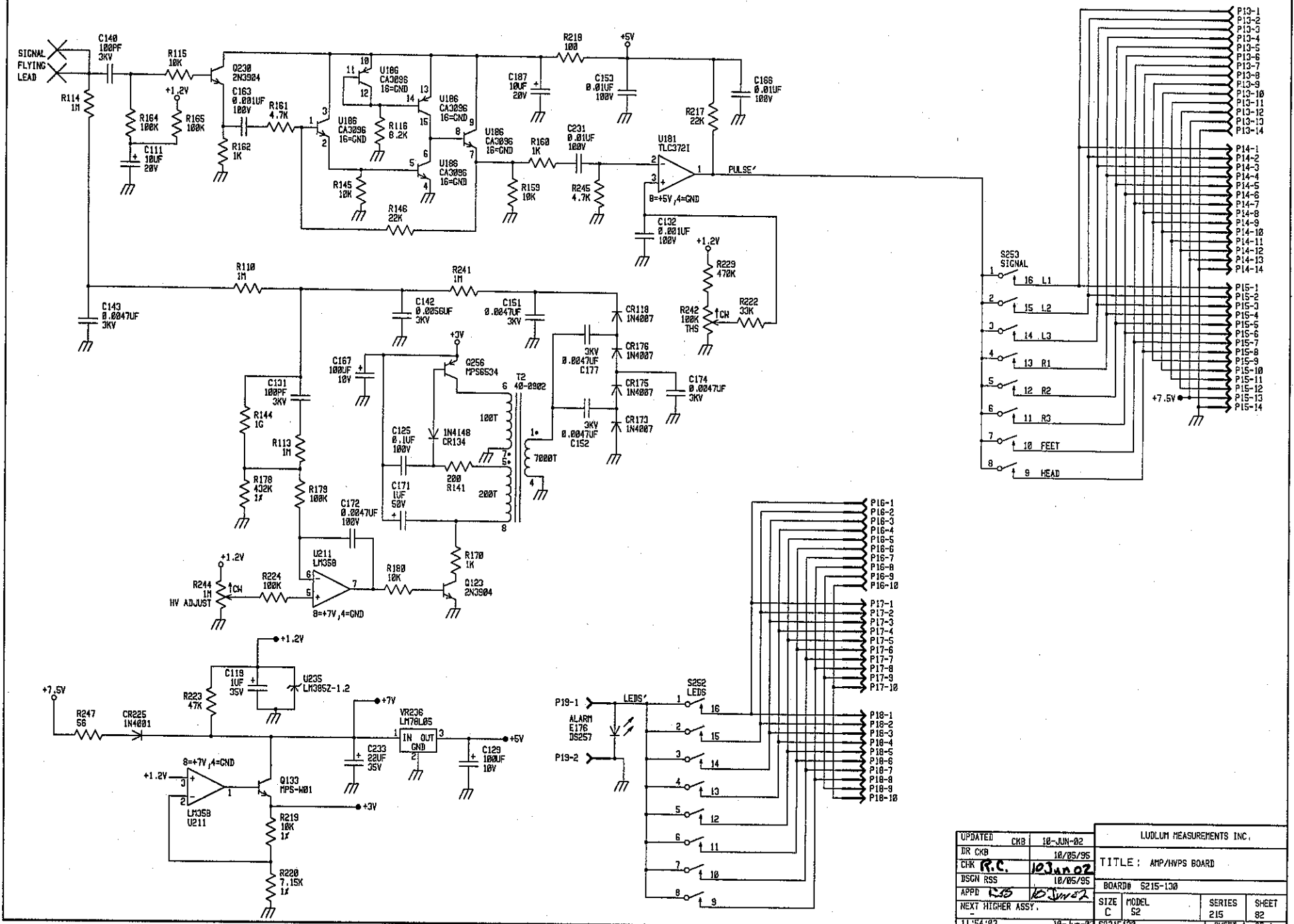

UPDATED	CKB	10-JUN-92	LUDLUM MEASUREMENTS INC.			
DR	CKB	10/05/95	TITLE: AMP/HVPS BOARD			
CHK	R.C.	10 JUN 92	BOARD# S215-130			
BSCN	RSS	10/05/95	SIZE	MODEL	SERIES	SHEET
APPD	R.S.	10 JUN 92	C	S2	215	82
NEXT HIGHER ASSY.						
11:54:03		10-JUN-92	S215130			SHEET 1 OF 1

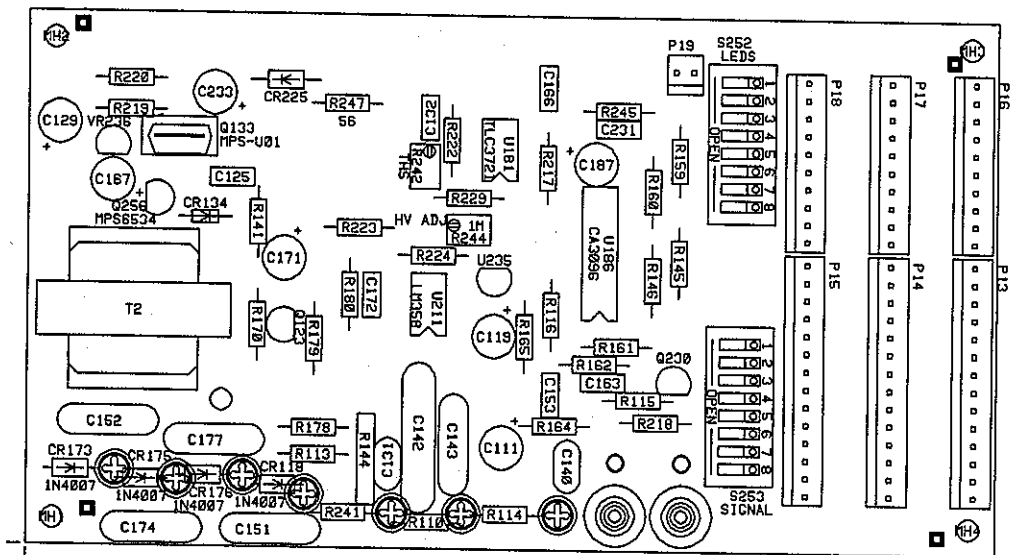

<input checked="" type="checkbox"/> LUDLUM MEASUREMENTS INC. SHEETWATER, TX.			
IN	ACF	16-JUL-99	TITLE: AMP/HVPS BOARD
CHK	RC	July 16, 99	BOARD: 5215-130
DSCN	RSS	05-OCT-95	MODEL: 52
APP	BS	7-16-99	FILENAME: 0S215130
COMPONENT	SOLDER	14:12:37	16-Jul-99
OUTLINE	OUTLINE	REVISION	SERIES SHEET
		1.0	215 83

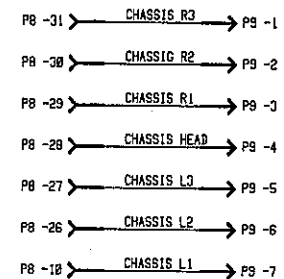
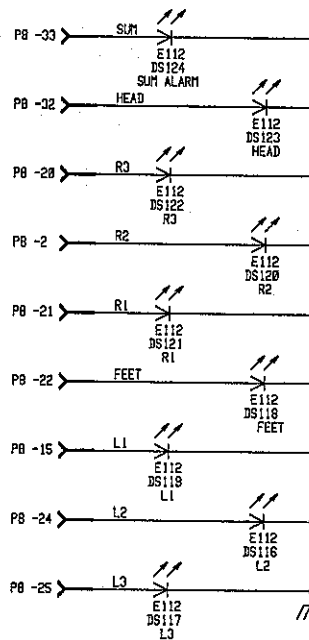
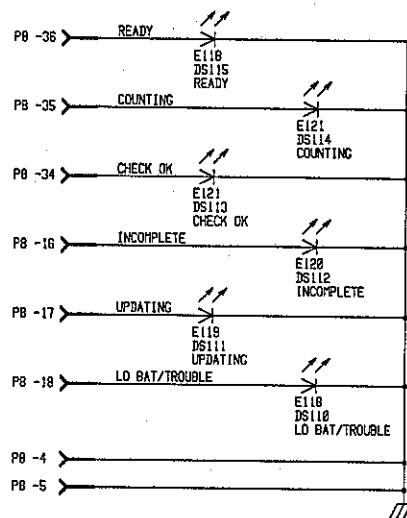

UPDATED	-	LUDLUM MEASUREMENTS INC.			
DR	ACF	21-JUL-99	TITLE: LED DISPLAY		
CHK	CKB	21-JUL-99	BOARD# S215-030		
DSGN	RDS	16-JUN-95	SIZE	MODEL	SERIES
APPD	RDS	21-JUL-99	C	52	215
NEXT HIGHER ASSY.			SHEET	63	
16738/12	21-JUL-99	S8215030	SHEET OF 1		

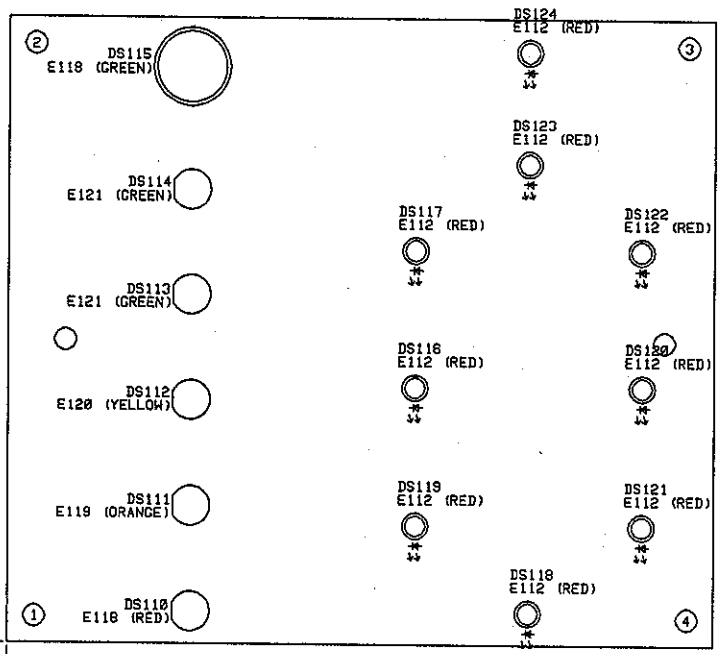

<input checked="" type="checkbox"/> LUDLUM MEASUREMENTS INC. SHEETWATER, TX.			
DR	ACF	21-JUL-99	TITLE: LED DISPLAY BOARD
CHK	KU3	21-JUL-99	BOARD: 5215-090
DSCN	RDS	16-AUG-95	MODEL: 52
APP	RDS	20-JUL-99	FILENAME: BS215B90
COMPONENT		SOLDER	16:29:12 21-Jul-99
OUTLINE	OUTLINE	REVISION	SERIES SHEET
		1.0	215 104

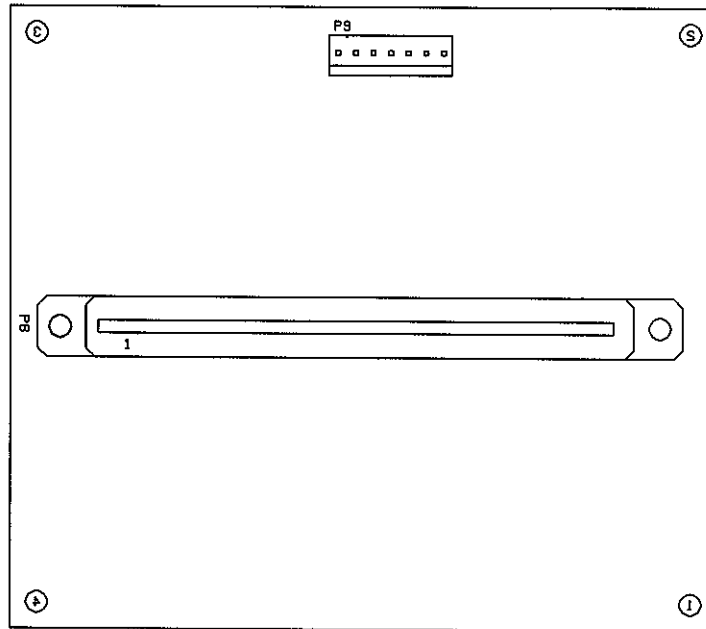

 LUDLUM MEASUREMENTS INC. SWEETWATER, TX.			
DR	ACF	21-JUL-99	TITLE: LED DISPLAY BOARD
CHK	AKS	21-JUL-99	BOARD# 5215-090 BS215090
DSGN	RDS	18-AUG-95	MODEL 52 SERIES 215 SHEET 104
APP	AKS	21-JUL-99	COMP ARTWRK <input type="checkbox"/> SLDR ARTWRK <input type="checkbox"/>
15:23:50		29-Nov-95	COMP OUTLINE <input type="checkbox"/> SLDR OUTLINE <input checked="" type="checkbox"/>
COMP PASTE	<input type="checkbox"/>	COMP MASK	<input type="checkbox"/> SLDR PASTE <input type="checkbox"/> SLDR MASK <input type="checkbox"/>

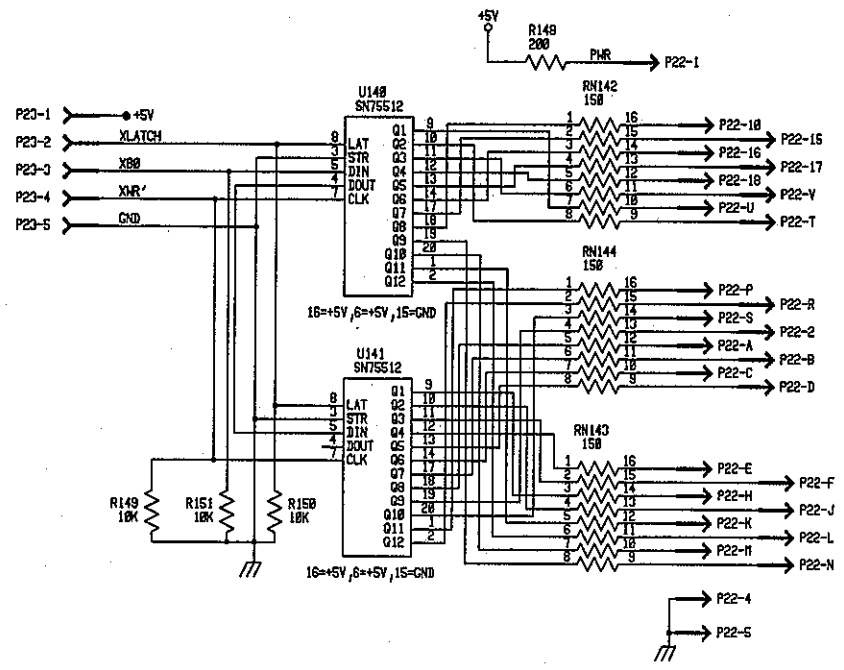

UPDATED	-	LUXUM MEASUREMENTS INC.			
DR RDS	06APR94	TITLE: LED DISPLAY DRIVER			
CHK	CKB 22-JUL-98	BOARD# 5420-005			
DSGN RDS	06APR94	SIZE	MODEL	SERIES	SHEET
APPD	ES 7-22-98	C	4901/4901-1/52	420	4
NEXT HIGHER ASSY:					
07:42:57	22-JUL-98	SB420005			SHEET OF 1

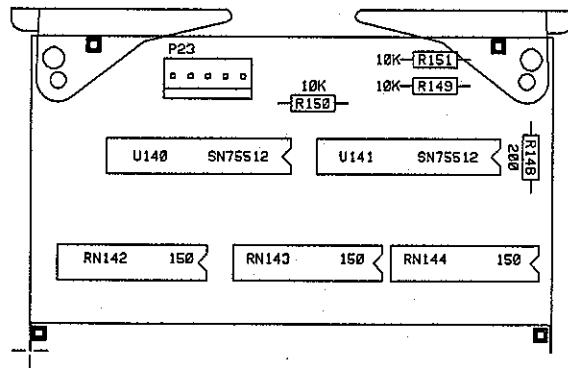

 LUDLUM MEASUREMENTS INC. SWEETWATER, TX.			
DR	RDS 07JUN94	TITLE: LED DRIVER	
CHK	CRD 22-07-98	BOARD#	5420-005 8S420005
DSCN	RDS 07JUN94	MODEL	4901/52 SERIES 420 SHEET 89
APP	BSS 2-22-98	07:44:11 22-JUL-98	
COMP PASTE <input type="checkbox"/>		COMP MASK <input type="checkbox"/>	
SLDR PASTE <input type="checkbox"/>		SLDR MASK <input type="checkbox"/>	

REVISIONS						
EFF	AUTHORITY	ZONE	LTR	DESCRIPTION	DATE	APPROVED

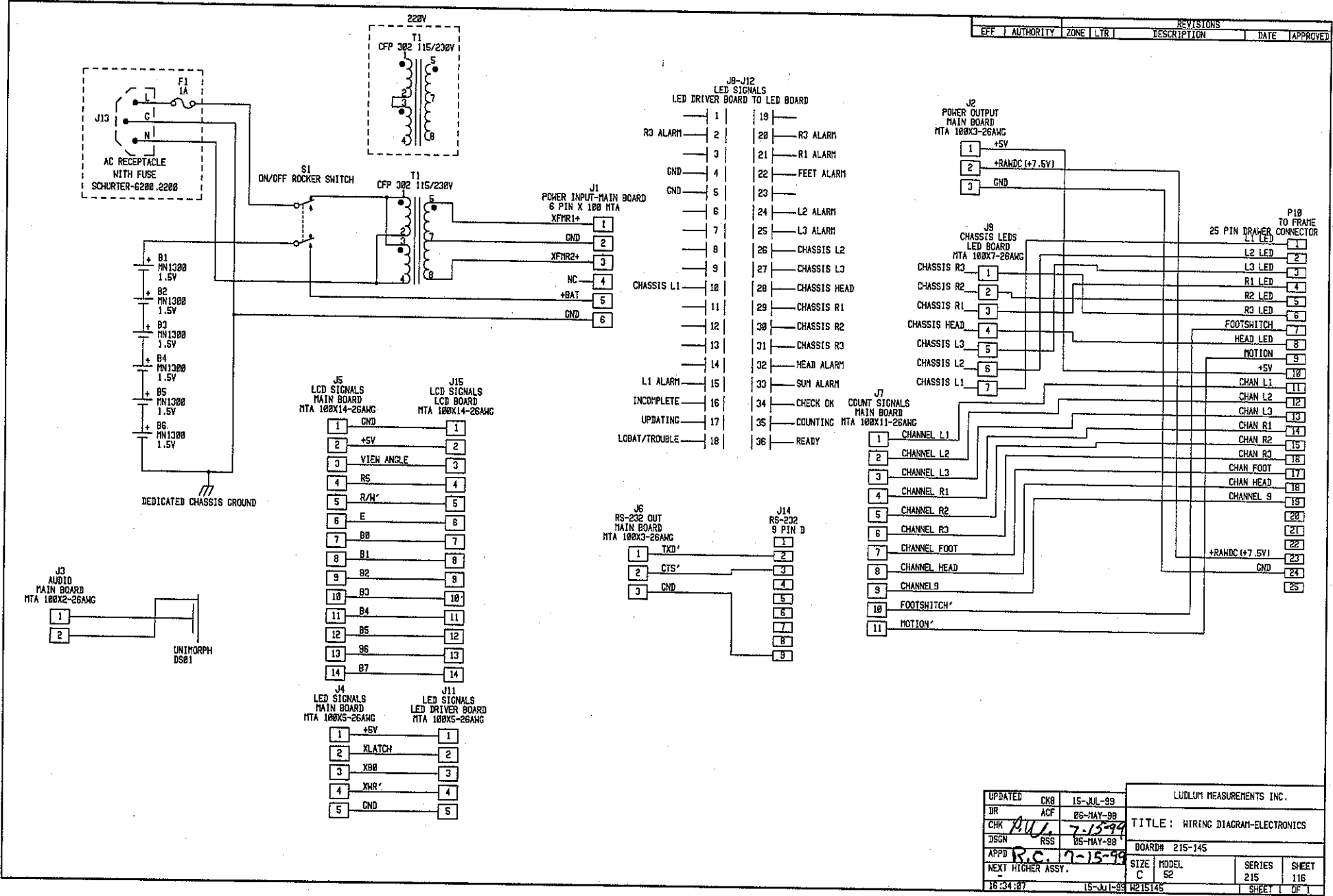

J9-J12 LED SIGNALS LED DRIVER BOARD TO LED BOARD

1	19
2	20
3	21
4	22
5	23
6	24
7	25
8	26
9	27
10	28
11	29
12	30
13	31
14	32
15	33
16	34
17	35
18	36

J2 POWER OUTPUT MAIN BOARD MTA 100X3-26AHC

1	+5V
2	+RANDC (+7.5V)
3	GND

J8 CHASIS LEADS LED BOARD MTA 100X7-26AHC

1	CHASSIS R3
2	CHASSIS R2
3	CHASSIS R1
4	CHASSIS HEAD
5	CHASSIS L3
6	CHASSIS L2
7	CHASSIS L1

J7 COUNT SIGNALS MAIN BOARD MTA 100X11-26AHC

1	CHANNEL L1
2	CHANNEL L2
3	CHANNEL L3
4	CHANNEL R1
5	CHANNEL R2
6	CHANNEL R3
7	CHANNEL FOOT
8	CHANNEL HEAD
9	CHANNEL 9
10	FOOTSWITCH
11	MOTION

P10 TO FRAME 25 PIN DRAWER CONNECTOR

1	L1 LED
2	L2 LED
3	L3 LED
4	R1 LED
5	R2 LED
6	R3 LED
7	FOOTSWITCH
8	HEAD LED
9	MOTION
10	+5V
11	CHAN L1
12	CHAN L2
13	CHAN L3
14	CHAN R1
15	CHAN R2
16	CHAN R3
17	CHAN FOOT
18	CHAN HEAD
19	CHANNEL 9
20	
21	
22	+RANDC (+7.5V)
23	GND
24	
25	

J5 LCD SIGNALS MAIN BOARD MTA 100X14-26AHC

1	GND
2	+5V
3	VIEN ANGLE
4	RS
5	R/W
6	E
7	B0
8	B1
9	B2
10	B3
11	B4
12	B5
13	B6
14	B7

J15 LCD SIGNALS LCD BOARD MTA 100X14-26AHC

1	GND
2	+5V
3	VIEN ANGLE
4	RS
5	R/W
6	E
7	B0
8	B1
9	B2
10	B3
11	B4
12	B5
13	B6
14	B7

J4 LED SIGNALS MAIN BOARD MTA 100X5-26AHC

1	+5V
2	XLATCH
3	XRB
4	XHR
5	GND

J11 LED SIGNALS LED DRIVER BOARD MTA 100X5-26AHC

1	GND
2	XLATCH
3	XRB
4	XHR
5	GND

J6 RS-232 OUT MAIN BOARD MTA 100X3-26AHC

1	TXD
2	CTS
3	GND

J14 RS-232 9 PIN D

1	
2	
3	
4	
5	
6	
7	
8	
9	

UPDATED	CK8	15-JUL-99	LUDLUM MEASUREMENTS INC.			
DR	ACF	05-MAY-98	TITLE: WIRING DIAGRAM-ELECTRONICS			
CHK	P.W.	7-15-99	BOARD# 215-145			
DSGN	RSS	05-MAY-98	SIZE	MODEL	SERIES	SHEET
APPD	R.C.	7-15-99	C	52	215	116
NEXT HIGHER ASSY.			R215145		SHEET 1 OF 1	
16:34:07	15-JUL-99					